

MD800 Series AC Drive (Multidrive System) System Design and Selection Guide



Preface

Brief Introduction

The MD800 series standard AC drive (multidrive system) is a new generation of standard multidrive product aimed at multidrive applications in the low-power market of traditional OEM industry. They are widely used in industries such as printing and packaging, woodworking machine tools, food and beverage, logistics and storage, textile printing and dyeing, and fans and pumps.

This user guide introduces the system composition, technical specifications, dimensions, detailed specifications and selection of options (installation accessories, cables, peripheral electrical components), as well as common EMC problem handling, and compliance certification and standards.

More Information

Name	Description
Quick Start Guide (Installation & Commissioning) (delivered with the product)	Describes the product installation, wiring, quick commissioning process, commissioning parameter table, and troubleshooting during commissioning.
System Design and Model Selection Guide (this document)	Describes the system composition, technical specifications, dimensions, detailed specifications and selection of options (installation accessories, cables, peripheral electrical components), as well as common EMC problem handling, and compliance certification and standards.
Maintenance and Repair Guide	Describes the routine product maintenance, component replacement, and troubleshooting.
Function Guide	Describes the commissioning tools, system commissioning steps, parameters, fault codes, and product functions and applications.
Communication Guide	Describes the communication mode, communication networking, and communication configuration of the product.

Revision History

Date	Version	Revision Description
March 2021	A00	First release.

Acquisition

This user guide is not shipped with the product. You can obtain the PDF version of this user guide by the following method:

Log in to Inovance's website (www.inovance.com), choose "**Support**" > "**Download**", search for keywords, and then download the PDF file.

Table of Contents

Preface	1
Fundamental Safety Instructions	4
1 Product Information	10
1.1 Nameplate	10
1.2 Product Model	12
1.3 Technical Data	13
1.3.1 Electrical Parameters	13
1.3.2 Technical Specifications	20
1.4 Components	23
1.5 System Composition	28
1.6 Options	29
2 Mechanical Design	31
2.1 Mounting Dimensions	31
2.2 Mounting Hole Dimensions	33
2.3 Clearance Requirements	34
2.4 Cooling Requirements	36
3 Electrical Design	43
3.1 Main Circuit Wiring	43
3.1.1 Main Circuit Terminals	43
3.1.2 Main Circuit Wiring Requirements	46
3.1.3 Lug Selection	49
3.1.4 Cable Selection for Main Circuit	51
3.2 Control Circuit Wiring	60
3.2.1 Control Circuit Terminals	60
3.2.2 Expansion Card Functions	67
3.2.3 Wiring Description of Control Circuit Terminals	78
3.2.4 Control Circuit Wiring Requirements	81
3.3 Communication Wiring	83
3.3.1 RS485 Communication Wiring	83
3.3.2 CAN Communication Wiring	84
3.3.3 Ethernet Wiring	86
3.4 Grounding	88
3.4.1 Main Circuit Grounding Requirements	88
3.4.2 Grounding of the Control Board	89
3.4.3 Grounding of a Single Device	89
3.4.4 Grounding of Multiple Devices	91
3.4.5 Grounding of the Cabinet System	92

4	Selection of Options	94
4.1	Electrical Peripherals	94
4.1.1	Fuse, Circuit Breaker, and Contactor	94
4.1.2	AC Input Reactor	94
4.1.3	Input Filter	97
4.1.3.1	EMC Filter	97
4.1.3.2	Simple Filter	102
4.1.4	Braking Components	104
4.1.5	Output Reactor	106
4.1.6	Magnetic Ring and Buckle	111
4.1.7	Motor	113
4.2	External LCD Operating Panel	115
5	Installation Requirements for Options	117
5.1	AC Input Reactor	117
5.2	Output Reactor	117
5.3	Fuse, Contactor, and Circuit Breaker	117
5.4	EMC Filter	117
5.5	Simple Filter	118
5.6	Magnetic Ring and Buckle	118
6	Solutions to Common EMC Interference Problems	121
6.1	RCD Malfunction	121
6.2	Harmonic Suppression	122
6.3	Control Circuit Interference	122
6.3.1	High-speed Pulse Interference	122
6.3.2	Common I/O Signal Interference	122
6.4	Communication Interference	123
6.4.1	RS485 and CAN Communication Interference	123
6.4.2	EtherCAT and PROFINET Communication Interference	123
7	Standards Compliance	125
7.1	Compliance with Certifications, Directives and Standards	125
7.2	CE Certification	125
7.2.1	Precautions for Compliance with European Standards	125
7.2.2	Conditions for Compliance with the EMC Directive	126
7.2.3	Conditions for Compliance with the LVD	128
7.3	UL or cUL Certification	128

Fundamental Safety Instructions

Safety Precautions

1. This chapter presents essential safety instructions for a proper use of the equipment. Before operating the equipment, read through the user guide and comprehend all the safety instructions. Failure to comply with the safety instructions may result in death, severe personal injuries, or equipment damage.
2. "CAUTION", "WARNING", and "DANGER" items in the user guide only indicate some of the precautions that need to be followed; they just supplement the safety precautions.
3. Use this equipment according to the designated environment requirements. Damage caused by improper use is not covered by warranty.
4. Inovance shall take no responsibility for any personal injuries or property damage caused by improper use.

Safety Levels and Definitions



Indicates that failure to comply with the notice will most likely result in death or severe personal injuries.



Indicates that failure to comply with the notice may result in death or severe personal injuries.



Indicates that failure to comply with the notice may result in minor or moderate personal injuries or equipment damage.

General Safety Instructions

- Drawings in the user guide are sometimes shown without covers or protective guards. Remember to install the covers or protective guards as specified first, and then perform operations in accordance with the instructions.
- The drawings in the user guide are shown for illustration only and may be different from the product you purchased.

Unpacking	
	<ul style="list-style-type: none">• Do not install the equipment if you find damage, rust, or signs of use on the equipment or accessories upon unpacking.• Do not install the equipment if you find water seepage or missing or damaged components upon unpacking.• Do not install the equipment if you find the packing list does not conform to the equipment you received.

**CAUTION**

- Check whether the packing is intact and whether there is damage, water seepage, dampness, and deformation before unpacking.
- Unpack the package by following the unpacking sequence. Do not strike the package violently.
- Check whether there is damage, rust, or injuries on the surface of the equipment and equipment accessories before unpacking.
- Check whether the package contents are consistent with the packing list before unpacking.

Storage and Transportation**WARNING**

- Large-scale or heavy equipment must be transported by qualified professionals using specialized hoisting equipment. Failure to comply may result in personal injuries or equipment damage.
- Before hoisting the equipment, ensure the equipment components such as the front cover and terminal blocks are secured firmly with screws. Loosely-connected components may fall off and result in personal injuries or equipment damage.
- Never stand or stay below the equipment when the equipment is being hoisted by the hoisting equipment.
- When hoisting the equipment with a steel rope, ensure the equipment is hoisted at a constant speed without suffering from vibration or shock. Do not turn the equipment over or let the equipment stay hanging in the air. Failure to comply may result in personal injuries or equipment damage.

**CAUTION**

- Handle the equipment with care during transportation and mind your steps to prevent personal injuries or equipment damage.
- When carrying the equipment with bare hands, hold the equipment casing firmly with care to prevent parts from falling. Failure to comply may result in personal injuries.
- Store and transport the equipment based on the storage and transportation requirements. Failure to comply will result in equipment damage.
- Avoid storing or transporting the equipment in environments with water splash, rain, direct sunlight, strong electric field, strong magnetic field, and strong vibration.
- Avoid storing the equipment for more than 6 months. Long-term storage requires stricter protection and necessary inspections.
- Pack the equipment strictly before transportation. Use a sealed box for long-distance transportation.
- Never transport the equipment with other equipment or materials that may harm or have negative impacts on this equipment.

Installation**DANGER**

- The equipment must be operated only by professionals with electrical knowledge.

 **WARNING**

- Read through the user guide and safety instructions before installation.
- Do not install this equipment in places with strong electric or magnetic fields.
- Before installation, check that the mechanical strength of the installation site can bear the weight of the equipment. Failure to comply will result in mechanical hazards.
- Do not wear loose clothes or accessories during installation. Failure to comply may result in an electric shock.
- When installing the equipment in a closed environment (such as a cabinet or casing), use a cooling device (such as a fan or air conditioner) to cool the environment down to the required temperature. Failure to comply may result in equipment over-temperature or a fire.
- Do not retrofit the equipment.
- Do not fiddle with the bolts used to fix equipment components or the bolts marked in red.
- When the equipment is installed in a cabinet or final assembly, a fireproof enclosure providing both electrical and mechanical protections must be provided. The IP rating must meet IEC standards and local laws and regulations.
- Before installing devices with strong electromagnetic interference, such as a transformer, install a shielding device for the equipment to prevent malfunction.
- Install the equipment onto an incombustible object such as a metal. Keep the equipment away from combustible objects. Failure to comply will result in a fire.

 **CAUTION**

- Cover the top of the equipment with a piece of cloth or paper during installation. This is to prevent unwanted objects such as metal chippings, oil, and water from falling into the equipment and causing faults. After installation, remove the cloth or paper on the top of the equipment to prevent over-temperature caused by poor ventilation due to blocked ventilation holes.
- Resonance may occur when the equipment operating at a constant speed executes variable speed operations. In this case, install the vibration-proof rubber under the motor frame or use the vibration suppression function to reduce resonance.

Wiring

 **DANGER**

- Equipment installation, wiring, maintenance, inspection, or parts replacement must be performed only by professionals.
- Before wiring, cut off all the power supplies of the equipment, and wait for at least the time designated on the equipment warning label before further operations because residual voltage still exists after power-off. After waiting for the designated time, measure the DC voltage in the main circuit to ensure the DC voltage is within the safe voltage range. Failure to comply will result in an electric shock.
- Do not perform wiring, remove the equipment cover, or touch the circuit board with power ON. Failure to comply will result in an electric shock.
- Check that the equipment is grounded properly. Failure to comply will result in an electric shock.

WARNING

- Do not connect the input power supply to the output end of the equipment. Failure to comply will result in equipment damage or even a fire.
- When connecting a drive to the motor, check that the phase sequences of the drive and motor terminals are consistent to prevent reverse motor rotation.
- Cables used for wiring must meet cross sectional area and shielding requirements. The shield of the cable must be reliably grounded at one end.
- Fix the terminal screws with the tightening torque specified in the user guide. Improper tightening torque may overheat or damage the connecting part, resulting in a fire.
- After wiring is done, check that all cables are connected properly, with no screws, washers, or exposed cables left inside the equipment. Failure to comply may result in an electric shock or equipment damage.

CAUTION

- During wiring, follow the proper electrostatic discharge (ESD) procedure, and wear an antistatic wrist strap. Failure to comply will damage the equipment or the internal circuits of the equipment.
- Use shielded twisted pairs for the control circuit. Connect the shield to the grounding terminal of the equipment for grounding purpose. Failure to comply will result in equipment malfunction.

Power-on

DANGER

- Before power-on, check that the equipment is installed properly with reliable wiring and the motor can be restarted.
- Check that the power supply meets equipment requirements before power-on to prevent equipment damage or a fire.
- After power-on, do not open the cabinet door or protective cover of the equipment, touch any terminal, or disassemble any unit or component of the equipment. Failure to comply will result in an electric shock.

WARNING

- Perform a trial run after wiring and parameter setting to ensure the equipment operates safely. Failure to comply may result in personal injuries or equipment damage.
- Before power-on, check that the rated voltage of the equipment is consistent with that of the power supply. Failure to comply may result in a fire.
- Before power-on, check that no one is near the equipment, motor, or machine. Failure to comply may result in death or personal injuries.





Operation

DANGER

- The equipment must be operated only by professionals. Failure to comply will result in death or personal injuries.
- Do not touch any connecting terminals or disassemble any unit or component of the equipment during operation. Failure to comply will result in an electric shock.



WARNING

- Do not touch the equipment casing, fan, or resistor with bare hands to feel the temperature. Failure to comply may result in personal injuries.
- Prevent metal or other objects from falling into the equipment during operation. Failure to comply may result in a fire or equipment damage.

Maintenance
<div style="border: 1px solid black; padding: 2px; display: inline-block;">  DANGER </div> <ul style="list-style-type: none"> ● Equipment installation, wiring, maintenance, inspection, or parts replacement must be performed only by professionals. ● Do not maintain the equipment with power ON. Failure to comply will result in an electric shock. ● Before maintenance, cut off all the power supplies of the equipment and wait for at least the time designated on the equipment warning label. ● In case of a permanent magnet motor, do not touch the motor terminals immediately after power-off because the motor terminals will generate induced voltage during rotation even after the equipment power supply is off. Failure to comply will result in an electric shock.
<div style="border: 1px solid black; padding: 2px; display: inline-block;">  WARNING </div> <ul style="list-style-type: none"> ● Perform routine and periodic inspection and maintenance on the equipment according to maintenance requirements and keep a maintenance record.
Repair
<div style="border: 1px solid black; padding: 2px; display: inline-block;">  DANGER </div> <ul style="list-style-type: none"> ● Equipment installation, wiring, maintenance, inspection, or parts replacement must be performed only by professionals. ● Do not repair the equipment with power ON. Failure to comply will result in an electric shock. ● Before inspection and repair, cut off all the power supplies of the equipment and wait for at least the time designated on the equipment warning label.
<div style="border: 1px solid black; padding: 2px; display: inline-block;">  WARNING </div> <ul style="list-style-type: none"> ● Require repair services according to the product warranty agreement. ● When the fuse is blown or the circuit breaker or earth leakage current breaker (ELCB) trips, wait for at least the time designated on the equipment warning label before power-on or further operations. Failure to comply may result in death, personal injuries, or equipment damage. ● When the equipment is faulty or damaged, the troubleshooting and repair work must be performed by professionals that follow the repair instructions, with repair records kept properly. ● Replace quick-wear parts of the equipment according to the replacement instructions. ● Do not use damaged equipment. Failure to comply may result in death, personal injuries, or severe equipment damage. ● After the equipment is replaced, check the wiring and set parameters again.
Disposal
<div style="border: 1px solid black; padding: 2px; display: inline-block;">  WARNING </div> <ul style="list-style-type: none"> ● Dispose of retired equipment in accordance with local regulations and standards. Failure to comply may result in property damage, personal injuries, or even death. ● Recycle retired equipment by observing industry waste disposal standards to avoid environmental pollution.

Safety Signs

For safe equipment operation and maintenance, comply with the safety labels on the equipment. Do not damage or remove the safety labels. See the following table for descriptions of the safety labels.

Safety Label	Description
	<ul style="list-style-type: none">● Read through the safety instructions before operating the equipment. Failure to comply may result in death, personal injuries, or equipment damage.● When the equipment is powered on or after the equipment is powered off, wait for at least the time designated on the equipment warning label before further operations. Failure to comply will result in an electric shock.

1 Product Information

1.1 Nameplate

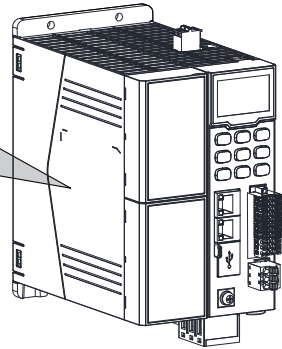
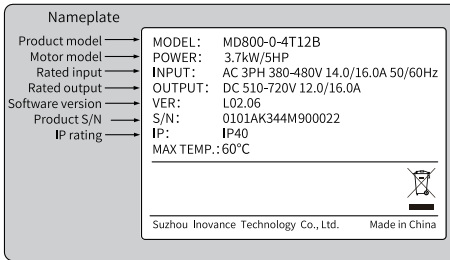

MD 800 - 0 - 4T 12 B

Code	Product Name
MD800	AC drive series

Code	Product Category
0	Power supply unit

Code	Voltage Class
4T	Three-phase 400 V
2S	Single-phase 200 V

Code	Braking Function
None	No braking unit
B	Built-in braking unit

Code	Rated Input Current
12	12

Figure 1-1 Nameplate and model number of the power supply unit

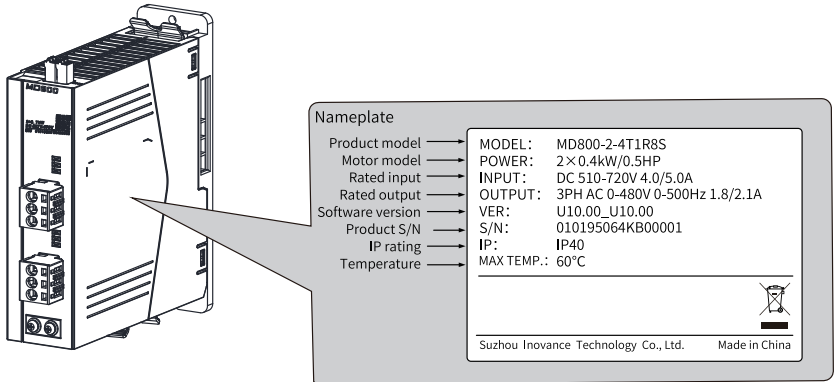

MD800 - 2 - 4T 1R8 S

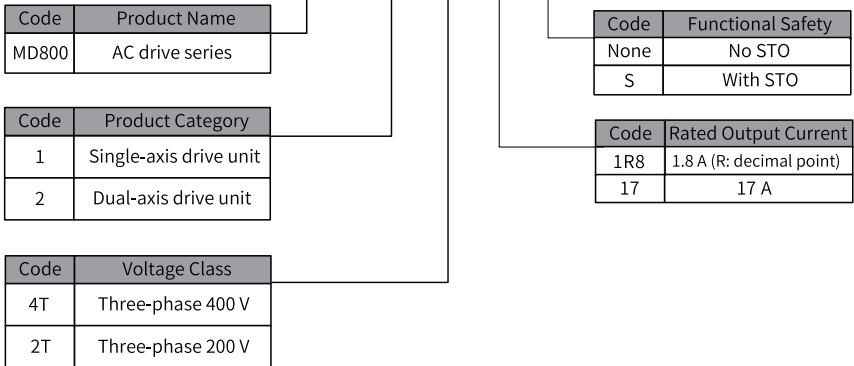

Figure 1-2 Nameplate and model number of the drive unit

1.2 Product Model

Table 1-1 Product models (three-phase 380-480 V)

Category	Power (kW)	Product Model	
Power supply unit	3.7	MD800-0-4T12	
		MD800-0-4T12B	
	7.5	MD800-0-4T22	
		MD800-0-4T22B	
	15	MD800-0-4T41	
		MD800-0-4T41B	
Drive unit (dual-axis)	0.4	MD800-2-4T1R8	
		MD800-2-4T1R8S	
	0.75	MD800-2-4T3R4	
		MD800-2-4T3R4S	
	1.5	MD800-2-4T4R8	
		MD800-2-4T4R8S	
	2.2	MD800-2-4T5R5	
		MD800-2-4T5R5S	
	3.7	MD800-2-4T9R5	
		MD800-2-4T9R5S	
	Drive unit (single-axis)	0.4	MD800-1-4T1R8
			MD800-1-4T1R8S
0.75		MD800-1-4T3R4	
		MD800-1-4T3R4S	
1.5		MD800-1-4T4R8	
		MD800-1-4T4R8S	
2.2		MD800-1-4T5R5	
		MD800-1-4T5R5S	
3.7		MD800-1-4T9R5	
		MD800-1-4T9R5S	
5.5		MD800-1-4T13	
		MD800-1-4T13S	
7.5		MD800-1-4T17	
		MD800-1-4T17S	

Table 1–2 Product models (single-phase 200–240 V)

Category	Power (kW)	Product Model
Power supply unit	2.2	MD800-0-2S24
		MD800-0-2S24B
	3.7	MD800-0-2S40
		MD800-0-2S40B
Drive unit (dual-axis)	0.2	MD800-2-2T1R7
		MD800-2-2T1R7S
	0.4	MD800-2-2T3
		MD800-2-2T3S
	0.75	MD800-2-2T5
		MD800-2-2T5S
	1.5	MD800-2-2T8
		MD800-2-2T8S
	2.2	MD800-2-2T11
		MD800-2-2T11S
Drive unit (single-axis)	0.2	MD800-1-2T1R7
		MD800-1-2T1R7S
	0.4	MD800-1-2T3
		MD800-1-2T3S
	0.75	MD800-1-2T5
		MD800-1-2T5S
	1.5	MD800-1-2T8
		MD800-1-2T8S
	2.2	MD800-1-2T11
		MD800-1-2T11S

1.3 Technical Data

1.3.1 Electrical Parameters

Three-phase 380–480 V

Table 1–3 Electrical parameters of the power supply unit (three-phase 380–480 V)

Item	Unit	Specifications		
Model: MD800-0-4T_ _ (B)	-	12	22	41
Power (heavy load)	kW	3.7	7.5	15
Power (light load)	kW	5.5	11	18.5
Size	-	S2		
Weight (gross/net)	kg	1.7/1.5	1.7/1.5	1.9/1.7

Item		Unit	Specifications		
Input	Rated input current (heavy load)	A	12	22	41
	Rated input current (light load)	A	16	33	44
	Power capacity (heavy load)	kVA	10	18.3	34.1
	Power capacity (light load)	kVA	13.3	27.4	36.6
	Mains type	-	TN, TT, IT		
	Rated voltage & Rated frequency	-	Three phase 380 VAC to 480 VAC, 50/60 Hz		
	Voltage range	-	-15% to +10%; actual allowed range: 323 VAC to 528 VAC		
	Frequency range	-	±5%; actual allowed range: 47 Hz to 63 Hz		
Output	Output voltage	V	510 VDC to 720 VDC		
	Rated output current (heavy load)	A	12.2	22.4	41.8
	Rated output current (light load)	A	16	33	44.6
	Efficiency (heavy load)	-	99.2%	99.2%	99.3%
	Efficiency (light load)	-	99.2%	99.1%	99.3%
	Overload capability	-	Heavy load: 60s for 150% with the rated current; Light load: 60s for 110% with the rated current		
Thermal design	Thermal design power (heavy load)	W	42	75	131
	Thermal design power (light load)	W	58	120	157
	Air flow	CFM	16	30	30
	Cooling mode	-	Forced air cooling		
Overvoltage category	-	OVC III			
Pollution degree	-	PD2			
IP rating	-	IP40 (excluding terminals and fans)			
Noise	dB(A)	33	60	60	

Table 1-4 Electrical parameters of the single-axis drive unit (three-phase 380–480 V)

Item	Unit	Specifications						
Model: MD800-1-4T_ _ (S)	-	1R8	3R4	4R8	5R5	9R5	13	17
Power (heavy load)	kW	0.4	0.75	1.5	2.2	3.7	5.5	7.5
Power (light load)	kW	0.75	1.5	2.2	3.7	5.5	7.5	11
Size	-	S1						
Weight (gross/net)	kg	1.1/0.9	1.1/0.9	1.1/0.9	1.1/0.9	1.1/0.9	1.1/0.9	1.1/0.9

Item		Unit	Specifications						
Input	Rated input current (heavy load)	A	2.3	4.2	6	6.9	11.8	16.2	21.2
	Rated input current (light load)	A	2.6	5.7	6.7	11.2	16.1	21.1	26
	Input voltage	-	510 VDC to 720 VDC						
Applicable motor	Heavy load	kW	0.4	0.75	1.5	2.2	3.7	5.5	7.5
	Light load		0.75	1.5	2.2	3.7	5.5	7.5	11
	Heavy load	HP	0.5	1	2	3	5	7.5	10
	Light load		1	2	3	5	7.5	10	15
Output	Output voltage	V	0 to AC input voltage						
	Output frequency	Hz	0 to 590						
	Rated output current (heavy load)	A	1.8	3.4	4.8	5.5	9.5	13	17
	Rated output current (light load)	A	2.1	4.6	5.4	9	13	17	21
	Efficiency (heavy load)	-	96.2%	97.0%	98.0%	98.4%	98.6%	98.7%	98.7%
	Efficiency (light load)	-	97.7%	98.0%	98.4%	98.4%	98.6%	98.6%	98.5%
Carrier frequency		kHz	V/f: 0.8 kHz to 15 kHz (6 kHz by default) SVC: 2 kHz to 7 kHz (6 kHz by default)						
Overload capability		-	Heavy load: 60s for 150% with the rated current Light load: 60s for 110% with the rated current						
Thermal design	Thermal design power (heavy load)	W	22	32	42	47	70	98	122
	Thermal design power (light load)	W	24	41	47	80	99	136	197
	Air flow	CFM	0	4	4	4	9.5	10	13
	Cooling mode	-	Natural air cooling	Forced air cooling					
Overvoltage category		-	OVC III						
Pollution degree		-	PD2						
IP rating		-	IP40 (excluding terminals and fans)						
Noise		dB(A)	0	33	33	33	47	51	59

Table 1-5 Electrical parameters of the dual-axis drive unit (three-phase 380-480 V)

Item	Unit	Specifications				
Model: MD800-2-4T_ _ (S)	-	1R8	3R4	4R8	5R5	9R5
Power (heavy load)	kW	0.4	0.75	1.5	2.2	3.7
Power (light load)	kW	0.75	1.5	2.2	3.7	5.5
Size	-	S1				
Weight (gross/net)	kg	1.3/1.1	1.3/1.1	1.3/1.1	1.3/1.1	1.3/1.1

Item		Unit	Specifications				
Input	Rated input current (heavy load)	A	4.5	8.5	12	13.7	23.7
	Rated input current (light load)	A	5.3	11.5	13.5	22.4	29.8
	Input voltage	-	510 VDC to 720 VDC				
Motor	Heavy load	kW	0.4	0.75	1.5	2.2	3.7
	Light load		0.75	1.5	2.2	3.7	5.5
	Heavy load	HP	0.5	1	2	3	5
	Light load		1	2	3	5	7.5
Output	Output voltage	V	0 to AC input voltage				
	Output frequency	Hz	0 to 590				
	Rated output current (heavy load)	A	1.8	3.4	4.8	5.5	9.5
	Rated output current (light load)	A	2.1	4.6	5.4	9	12
	Efficiency (heavy load)	-	96.1%	97.0%	97.9%	98.4%	98.6%
	Efficiency (light load)	-	97.7%	98.0%	98.4%	98.4%	98.6%
Carrier frequency		kHz	V/f: 0.8 kHz to 15 kHz (6 kHz by default) SVC: 2 kHz to 7 kHz (6 kHz by default)				
Overload capability		-	Heavy load: 60s for 150% with the rated current Light load: 60s for 110% with the rated current				
Thermal design	Thermal design power (heavy load)	W	45	64	85	98	141
	Thermal design power (light load)	W	49	82	95	163	198
	Air flow	CFM	4	4	6	9.5	13
	Cooling mode	-	Forced air cooling				
Overvoltage category		-	OVC III				
Pollution degree		-	PD2				
IP rating		-	IP40 (excluding terminals and fans)				
Noise		dB(A)	33	33	44	47	59

Single-phase 200–240 V

Table 1–6 Electrical parameters of the power supply unit (single-phase 200–240 V)

Item	Unit	Specifications	
Model: MD800-0-2S_ _ (B)	-	24	40
Power (heavy load)	kW	2.2	3.7
Power (light load)	kW	3	4.4
Size	-	S2	
Weight (gross/net)	kg	1.7/1.5	1.9/1.7

Item		Unit	Specifications			
Input	Rated input current (heavy load)	A	24		40	
	Rated input current (light load)	A	27		44	
	Power capacity (heavy load)	kVA	5.8		9.6	
	Power capacity (light load)	kVA	6.5		10.6	
	Mains type	-	TN, TT, IT			
	Rated voltage & Rated frequency	-	Single-phase 200 VAC to 240 VAC, 50/60 Hz			
	Voltage range	-	-15% to +10%; actual allowed range: 170 VAC to 264 VAC			
	Frequency range	-	±5%; actual allowed range: 47 Hz to 63 Hz			
Output	Output voltage	V	270 VDC to 360 VDC			
	Rated output current (heavy load)	A	13.5		22.6	
	Rated output current (light load)	A	15.1		24.8	
	Efficiency (heavy load)	-	98.1%		98.1%	
	Efficiency (light load)	-	98.7%		98.1%	
	Overload capability	-	Heavy load: 60s for 150% with the rated current Light load: 60s for 110% with the rated current			
Thermal design	Thermal design power (heavy load)	W	59		94	
	Thermal design power (light load)	W	65		110	
	Air flow	CFM	25		30	
	Cooling mode	-	Air cooling			
Overvoltage category	-	OVC III				
Pollution degree	-	PD2				
IP rating	-	IP40 (excluding terminals and fans)				
Noise	dB(A)	53		60		

Table 1-7 Electrical parameters of the single-axis drive unit (single-phase 200–240 V)

Item	Unit	Specifications				
Model: MD800-1-2T_ _ (S)	-	1R7	3	5	8	11
Power (heavy load)	kW	0.2	0.4	0.75	1.5	2.2
Power (light load)	kW	0.4	0.75	1.5	2.2	3.7
Size	-	S1				
Weight (gross/net)	kg	1.1/0.9	1.1/0.9	1.1/0.9	1.1/0.9	1.1/0.9

Item		Unit	Specifications				
Input	Rated input current (heavy load)	A	2.1	3.7	6.2	10	13.7
	Rated input current (light load)	A	2.4	4.4	10	12	22
	Input voltage	-	270 VDC to 360 VDC				
Motor	Heavy load	kW	0.2	0.4	0.75	1.5	2.2
	Light load		0.4	0.75	1.5	2.2	3.7
	Heavy load	HP	0.3	0.5	1	2	3
	Light load		0.5	1	2	3	5
Output	Output voltage	V	0 to AC input voltage				
	Output frequency	Hz	0 to 590				
	Rated output current (heavy load)	A	1.7	3	5	8	11
	Rated output current (light load)	A	1.9	3.5	8	9.6	17.6
	Efficiency (heavy load)	-	97.1%	97.4%	97.6%	98.3%	98.2%
	Efficiency (light load)	-	98.3%	98.3%	98.3%	98.5%	98.5%
Carrier frequency		kHz	V/f: 0.8 kHz to 15 kHz (6 kHz by default) SVC: 2 kHz to 7 kHz (6 kHz by default)				
Overload capability		-	Heavy load: 60s for 150%; Light load: 60s for 110%				
Thermal design	Thermal design power (heavy load)	W	9	15	26	34	53
	Thermal design power (light load)	W	10	18	35	43	61
	Air flow	CFM	0	4	4	4	10
	Cooling mode	-	Natural air cooling	Forced air cooling			
Overvoltage category		-	OVC III				
Pollution degree		-	PD2				
IP rating		-	IP40 (excluding terminals and fans)				
Noise		dB(A)	0	33	33	33	33

Table 1-8 Electrical parameters of the dual-axis drive unit (single-phase 200-240 V)

Item		Unit	Specifications				
Model: MD800-2-2T_ _ (S)		-	1R7	3	5	8	11
Power (heavy load)		kW	0.2	0.4	0.75	1.5	2.2
Power (light load)		kW	0.4	0.75	1.5	2.2	-
Size		-	S1				
Weight (gross/net)		kg	1.3/1.1	1.3/1.1	1.3/1.1	1.3/1.1	1.3/1.1

Item		Unit	Specifications				
Input	Rated input current (heavy load)	A	4.3	7.5	12.5	20	27.5
	Rated input current (light load)	A	4.8	8.8	20	24	44
	Input voltage	-	270 VDC to 360 VDC				
Motor	Heavy load	kW	0.2	0.4	0.75	1.5	2.2
	Light load		0.4	0.75	1.5	2.2	3.7
	Heavy load	HP	0.3	0.5	1	2	3
	Light load		0.5	1	2	3	5
Output	Output voltage	V	0 to AC input voltage				
	Output frequency	Hz	0 to 590				
	Rated output current (heavy load)	A	1.7	3	5	8	11
	Rated output current (light load)	A	1.9	3.5	8	9.6	17.6
	Efficiency (heavy load)	-	97.0%	97.4%	97.6%	98.3%	98.2%
	Efficiency (light load)	-	98.3%	98.3%	98.3%	98.5%	98.50%
Carrier frequency		kHz	V/f: 0.8 kHz to 15 kHz (6 kHz by default) SVC: 2 kHz to 7 kHz (6 kHz by default)				
Overload capability		-	Heavy load: 60s for 150% with the rated current; Light load: 60s for 110% with the rated current				
Thermal design	Thermal design power (heavy load)	W	18	29	51	69	109
	Thermal design power (light load)	W	20	35	69	87	122
	Air flow	CFM	4	4	7	7	13
	Cooling mode	-	Forced air cooling				
Overvoltage category		-	OVC III				
Pollution degree		-	PD2				
IP rating		-	IP40 (excluding terminals and fans)				
Noise		dB(A)	33	33	33	45	59

1.3.2 Technical Specifications

Table 1-9 General specifications

Item		Specifications
Environment	Operating location	Indoors
	Operating ambient temperature	-20°C to +60°C Temperature change less than 0.5 °C/min For applications with normal load: Derating of rated current by 2.5% per 1°C rise when above 50°C; Maximum temperature: 60°C For overload applications: Derating of rated current by 2.5% per 1°C rise when above 40°C; Maximum temperature: 60°C
	Storage temperature	-40°C to +70°C
	Transportation temperature	-40°C to +70°C
	Relative humidity in work environment	Relative humidity range: 5% to 95% Standard models cannot be used in environments with corrosive gases. Select models with corrosion-resistant coated housing for such environments.
	Relative humidity for storage	5% to 95%
	Relative humidity for transportation	Lower than 95% at +40°C
	Altitude	The maximum altitude of the star power grid is 4000 m (13123 ft), and the maximum altitude of delta power grid is 2000 m (6562 ft). De-rated by 1% per 100 m increase when the altitude is above 1000 m.
	Vibration	When transported in transport packages: conforming to EN 60721-3-2, Class 2M3 When package removed: conforming to ISTA 1H

Table 1-10 Technical specifications of the power supply unit

Item		Specifications
Protections		Overtemperature protection, power phase loss protection, overvoltage protection, and braking transistor short circuit detection
HMI	Communication/Bus	Modbus-RTU protocol supported: maximum baud rate of 115200 bps; up to 128 nodes; maximum distance of 1000 m CANOpen protocol supported: maximum baud rate of 1 Mbps; up to 127 nodes; maximum distance of 1000 m CANlink protocol supported: maximum baud rate of 1 Mbps; up to 63 nodes; maximum distance of 1000 m PROFINET RT supported: maximum baud rate of 100 Mbps; full duplex mode; up to 65535 nodes; maximum distance of 100 m EtherCAT protocol supported: maximum baud rate of 100 Mbps; full duplex mode; up to 65535 nodes; maximum distance of 100 m
	Analog input	AI1 and AI2 are programmable to support -10 V to +10 V/0 to 20 mA. Their resolution is 12-bit, correction accuracy is 0.3%, and input impedance is 22 k Ω for voltage input and 500 Ω for current input. Temperature detection for PT100, PT1000, KTY-84-130, and PTC-130 is available.
	Digital input and output	DI1 to DI4 are ordinary DIs whose response time is 10 ms. They do not support for high-speed pulse input. Their input frequency is lower than 100 Hz. Photocoupler isolation is supported and they are compatible with bipolar input. The input impedance is 3.3 k Ω and the effective level input voltage range is 15–30 V DIO1 to DIO4 are general multifunction input/output terminals, which can be set by parameters. When they are used as DI terminals, their specifications are consistent with that of DI1 to DI4. When they are used as output terminals, they provide the common collector open-drain output function and cannot be directly connected to the power supply. A pull-up resistor is required for connecting them to the power supply and the impedance is determined by the load requirements. The maximum output capacity is 24 VDC/50 mA.
	Relay output	TA-TB: NC; TA-TC: NO; Contact capacity: 30 VDC/3 A, 250 VAC/3 A (Cos ϕ = 0.4)
	Operating panel display	The standard configuration includes 7-digit LED digit display, multiple symbol display, and nine function keys, in which two green digits indicate the axis number and five white digits indicate the content. The symbols indicate the units and states.

Table 1–11 Technical specifications of the drive unit

	Item	Specifications
Basic parameters	Load type	Motor type: Synchronous motor/Asynchronous motor
	Output frequency resolution	Digital setting: 0.01 Hz Analog setting: Maximum frequency x 0.025%
	Carrier frequency	V/f control: 0.8 kHz to 15 kHz (6 kHz by default) SVC: 2 kHz to 7 kHz (6 kHz by default) The carrier frequency is automatically adjusted based on heatsink temperature.
	Motor type and control mode	Three-phase asynchronous motor: V/f control, sensorless vector control (SVC) PMSM: SVC
	Speed range	1:50 (asynchronous motor V/f control) 1:100 (asynchronous motor, SVC)
	Speed control accuracy	±1.0% (V/f control) ±0.5% (SVC)
	Speed fluctuation	±0.5% (SVC)
	Torque response	< 20 ms (SVC)
	Torque control accuracy	±5% (SVC) (above 10 Hz)
	Torque control mode	SVC
	Overload capability	1 h for 115% of the rated current, 1 min for 150% of the rated current, 2s for 178% of the rated current
	Torque boost	Automatic boost; customized boost 0.1% to 30.0%
	V/f curve	Linear V/f curve; Multi-point V/f curve; Square V/f curve; Complete V/f separation; Half V/f separation
Protections	Short circuit to ground upon power-on, inter-phase short circuit, motor overtemperature (PTC), drive overcurrent, drive overload (output power limit), motor overload, drive overvoltage, drive undervoltage, drive stall in SVC mode, drive overtemperature, output phase loss, communication fault, current detection fault, motor auto-tuning fault, EEPROM reading-writing fault, locked-rotor protection, excessive speed deviation, stall alarm	

	Item	Specifications
Customized functions	Acceleration/Deceleration curve	Linear curve, S-curve mode 1, S-curve mode 2
	Built-in PID	The system implements the Proportional-Integral-Derivative (PID) function (two groups of parameters) in the closed-loop control.
	Running command channel	Three channels are provided, including LED operating panel or external LCD operating panel setting, control terminal setting, and communication setting, which can be switched over in various ways.
	Frequency source	Eight frequency sources are provided, including digital setting, analog voltage setting, analog current setting, communication setting, PID, multi-speed, and built-in simple PLC. You can perform switchover between these sources in various ways.
	Wobble function	Various triangular wave frequency control functions are provided.

1.4 Components

Components of the Power Supply Unit

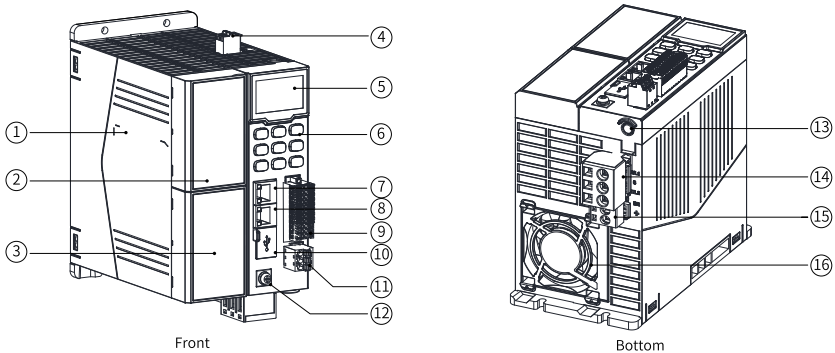

Figure 1-3 Components of the power supply unit

Table 1-12 Description of the components of power supply unit

No.	Component Name	Description
1	Nameplate	Used to display the product information.
2	Position of optional expansion card 1	Used to install optional expansion card 1.
3	Position of expansion card 2	Used to install optional expansion card 2. It is recommended that the Ethernet card be installed at this position.

No.	Component Name	Description
4	24 V input terminal	External 24 V control power input With the external 24V power supply input, even after the main circuit is powered off, the control part can still work normally, without affecting the communication, parameter setting, fault information query, and other operations.
5	LED display on the operating panel	Includes the axis number, status, unit and data display.
6	Keys on the operating panel	Used for operations through the operating panel.
7	Communication terminal (CN3)	CAN communication terminal, which can also be used to connect GP-inolink for software upgrade and commissioning
8	Communication terminal (CN4)	Used for CAN communication. It can also be used to connect GP-inolink or SOP-20 for software upgrade and commissioning.
9	Control terminal (CN1)	Integrates MODBUS communication, analog input, digital input, digital output, + 24V power output, and +10V power output signals.
10	Type-C USB commissioning interface, termination resistor DIP switch (CN5)	Used as the Type-C USB commissioning interface to connect the computer for software upgrade and commissioning, MODBUS communication termination resistor DIP switch in built-in CN1, or CAN communication termination resistor DIP switch in built-in CN3 and CN4.
11	Relay terminal (CN2)	Used for relay output.
12	Grounding terminal	Used for protective grounding.
13	Optional grounding screw	Used for grounding (optional) of the control board.
14	R(L1)/S/T(L2) input terminals	Used to connect the three-phase/single-phase AC input power supply. (R/S/T for three-phase power supply, and L1/L2 for single-phase power supply).
15	BR/+ braking terminal (optional)	Used to connect the braking resistor.
16	Cooling fan	Used for heat dissipation.

Components of the Drive Unit

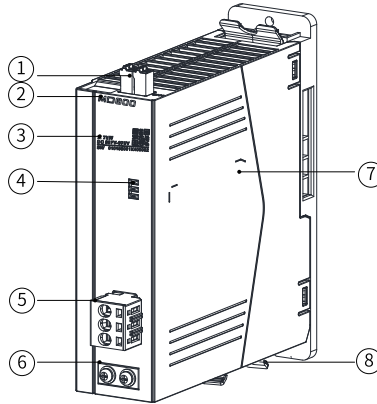

Figure 1-4 Components of the drive unit (single-axis)

Table 1-13 Description of the components of drive unit (single-axis)

No.	Component Name	Description
1	STO terminal (optional)	Used as the optional STO terminal.
2	Product model	Used to display the product series.
3	Power, voltage class, QR code, serial number	Used to display the power, voltage class, QR code, and serial number of the product.
4	Indicators	Used as indicators of output terminals.
5	U/V/W output terminals	Used to connect the three-phase motor.
6	2-M4 screw grounding terminal	Two grounding (PE) terminals used for protective grounding.
7	Nameplate	Used to display the product information.
8	Cooling fan	Cooling fan

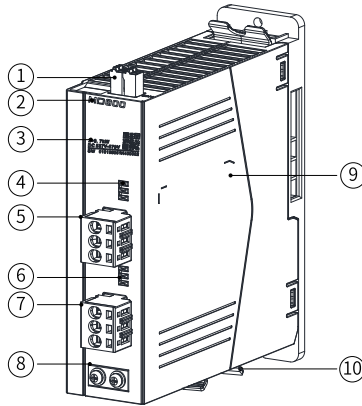

Figure 1-5 Components of the drive unit (dual-axis)

Table 1-14 Description of the components of drive unit (dual-axis)

No.	Component Name	Description
1	STO terminal (optional)	Used as the optional STO terminal.
2	Product series	Used to display the product series.
3	Power, voltage class, QR code, serial number	Used to display the power, voltage class, QR code, and serial number of the product.
4	Indicator of output axis 1	Used as the indicator of output terminal 1.
5	Output terminal of U1/V1/W1 axis 1	Used as output terminal 1 of the AC drive to connect the three-phase motor.
6	Indicator of output axis 2	Used as the indicator of output terminal 2.
7	Output terminal of U2/V2/W2 axis 2	Used as output terminal 2 of the AC drive to connect the three-phase motor.
8	2-M4 screw grounding terminal	Two grounding (PE) terminals used for protective grounding.
9	Nameplate	Used to display the product information.
10	Cooling fan	Used for heat dissipation.

Components of the Filter Unit

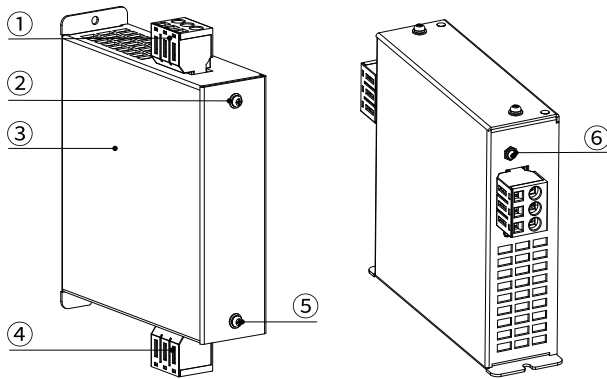

Figure 1-6 Components of the filter unit

Table 1-15 Description of the components of filter unit

No.	Component Name	Description
1	R/L1, S, T/L2 input terminals	Used for power input.
2	Input grounding screw	Used for input grounding.
3	Nameplate	Used to display the product information.
4	R'/L1', S', T'/L2' output terminals	Used to connect the power supply unit.
5	Output M4 grounding screw	Used for output grounding.
6	Optional EMC screw	Used for EMC grounding (optional).

1.5 System Composition

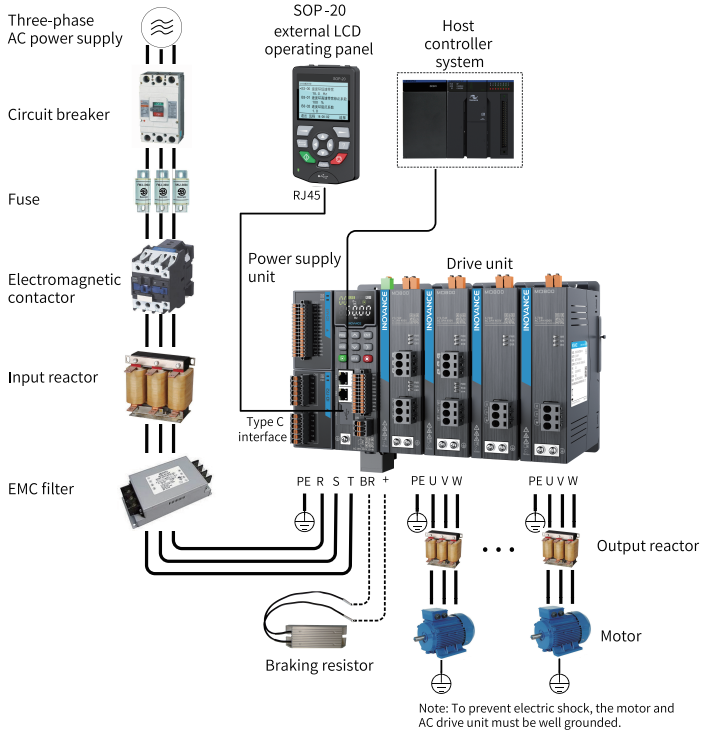

Figure 1-7 MD800 series system connection

Table 1-16 Function description of MD800 system peripherals

Component Name	Installation Position	Function Description
Circuit breaker	Between the power supply and input side of the power supply unit	MCCB: Cuts off power supply when overcurrent occurs on downstream devices. Earth leakage circuit breaker: Provides protection against potential leakage current during drive running to prevent electric shock and even a fire.
Fuse	Between the power supply and input side of the power supply unit	Protects downstream semiconductors of the power supply unit in case of short circuits.
Electromagnetic contactor	Between the circuit breaker and input side of the power supply unit	Switches ON/OFF the drive. Do not start/stop the drive frequently using the contactor (keep an interval of at least 1 hour between ON and OFF operations) or use it to directly start the drive.

Component Name	Installation Position	Function Description
Input reactor	Input side of the power supply unit	Improves the power factor of the power input side. Eliminates higher harmonics of the input side effectively and prevents damage to other devices caused by the distortion of voltage waveform. Eliminate input current unbalance due to inter-phase unbalance. Generally, for high pollution and low quality power grids, it is recommended to install input reactors.
EMC filter	Input side of the power supply unit	Reduces external conduction and radiation interference of the drive. Decreases conduction interference flowing from the power supply to the drive and improves the anti-interference capacity of the drive.
Braking resistor	Input side of the power supply unit	Dissipates regenerated energy during motor deceleration.
Output reactor	Between the output side of the drive unit and the motor, close to the drive	The output side of drive generally has much higher harmonics. When the motor is far from the drive, there is high distributed capacitance in the circuit, and certain harmonics may cause resonance in the circuit, which will: a) Degrade motor insulation performance and damage motor in long run. b) Generate large leakage current and cause frequent Drive drive protection trips. If the distance between the AC drive and the motor is longer than 100 m, it is recommended that an AC output reactor be installed.
dv/dt reactor	At the output side of the drive unit and close to the drive	Optional. Protects motor insulation and reduces bearing current.
Output magnetic ring	At the output side inside the drive unit	Reduces bearing current.
Motor	At the output side of the drive	Select an appropriate motor.
SOP-20 external LCD operating panel	Connected to the CN4 terminal through a network cable	Optional for commissioning and parameter setting.

1.6 Options

In some applications, the I/O resources may be insufficient, Ethernet bus may be required, and EMC problems such as leakage current, signal interference, and long cable applications may occur. To meet these requirements, you can select the following options.

Table 1–17 Options

Category		Unit Model	Option Model
Expansion card	Multi-functional card	All power supply units	IO-M1
	Single-contact relay expansion card	All power supply units	IO-R1
	Double-contact relay expansion card	All power supply units	IO-R2
	PROFINET communication extension card	All power supply units	SI-PN
	EtherCAT communication expansion card	All power supply units	SI-ECAT
Operating panel	LCD operating panel	All power supply units	SOP-20
	External operating panel network cable	All power supply units	C45590-GNCN-25003
EMC shielded bracket	Shielded bracket for the power supply unit	All power supply units	/
	Shielded bracket for the drive unit	All drive units	/
Input reactor	Input reactor	For details about the applicable power supply unit models and option models, see "4.1.2 AC Input Reactor" on page 94 AC Input Reactor .	
EMC filter	Schaffner C2 filter	For details about the applicable power supply unit models and option models, see "4.1.3.1 EMC Filter" on page 97 EMC Filter .	
	Inovance C2 filter	For details about the applicable power supply unit models and option models, see "4.1.3.1 EMC Filter" on page 97 EMC Filter .	
Output reactor	Output reactor (Schaffner)	For details about the applicable drive unit models and option models, see "4.1.5 Output Reactor" on page 106 Output Reactor .	
	Output reactor (Inovance)	For details about the applicable drive unit models and option models, see "4.1.5 Output Reactor" on page 106 Output Reactor .	
Magnetic ring	Magnetic ring	All drive units	DY644020H
		All drive units	DY805020H
		All drive units	DY1207030H

2 Mechanical Design

2.1 Mounting Dimensions

Power Supply Unit

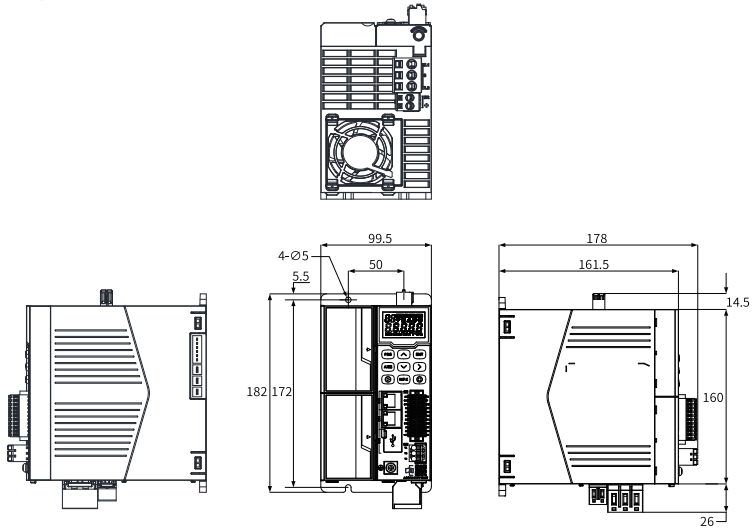

Figure 2-1 Overall and mounting dimensions of the power supply unit (unit: mm)

Drive Unit (Single-axis)

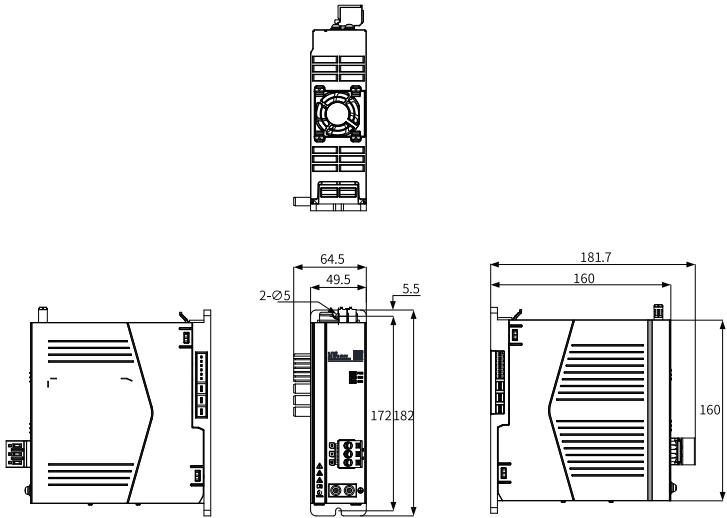

Figure 2-2 Overall and mounting dimensions of the single-axis drive unit (unit: mm)

Drive Unit (Dual-axis)

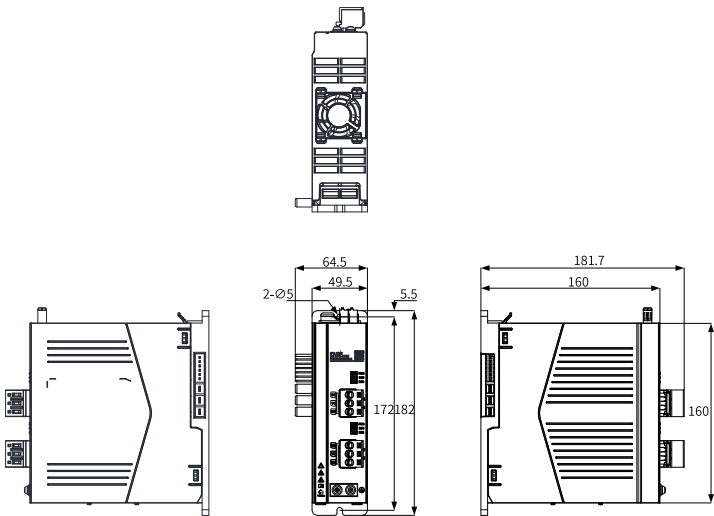

Figure 2-3 Overall and mounting dimensions of the dual-axis drive unit (unit: mm)

Filter Unit

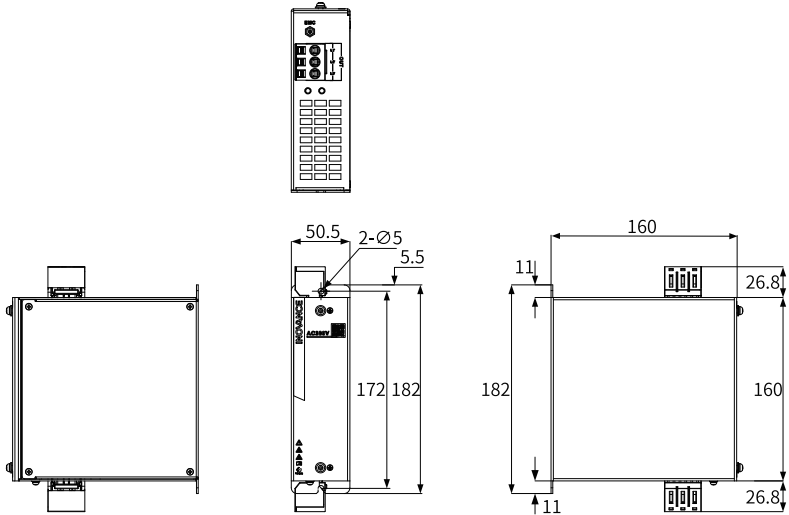

Figure 2-4 Overall and mounting dimensions of the filter unit (unit: mm)

2.2 Mounting Hole Dimensions

As the MD800 series units are booksize units with equal height and width, mounting holes with equal spacing are adopted. The longitudinal spacing of the mounting holes is 172 mm and the transverse spacing is 50 mm. The recommended clearance for good heat dissipation is at least 55 mm on the left and right and at least 200 mm on the top and bottom of the mounting holes.

The following shows the example of mounting hole dimensions, in which one power supply unit is connected to five drive units.

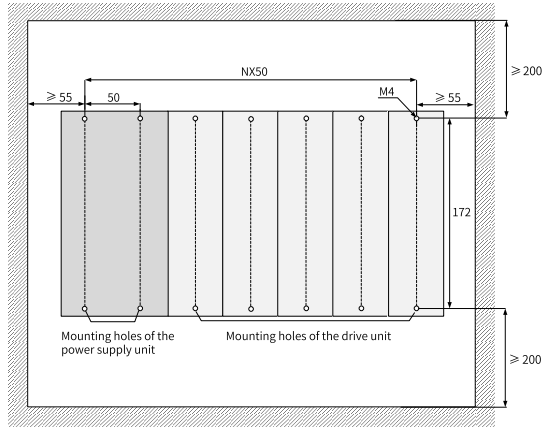

Figure 2-5 Mounting hole dimensions (unit: mm)

2.3 Clearance Requirements

The recommended installation methods of MD800 include single rack installation and multiple rack installation.

- When only a single unit is installed, the required reserved clearance around the unit is shown in the following figure.

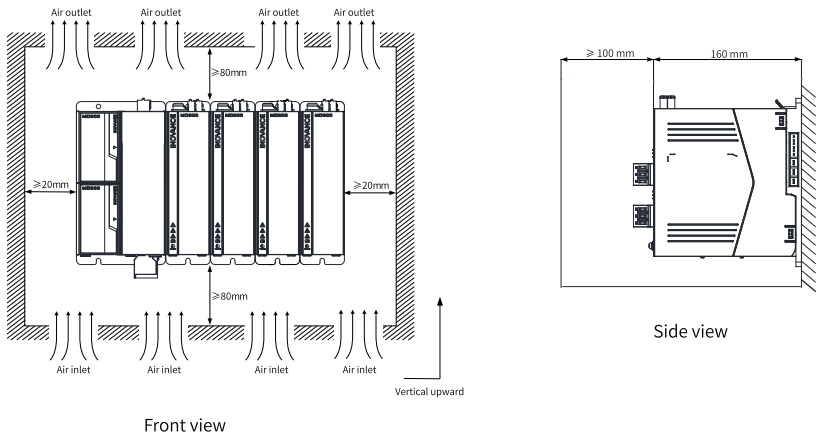

Figure 2-6 Installation clearance (single unit)

- When multiple units are installed side by side, the minimum distance between two units is 50 mm.

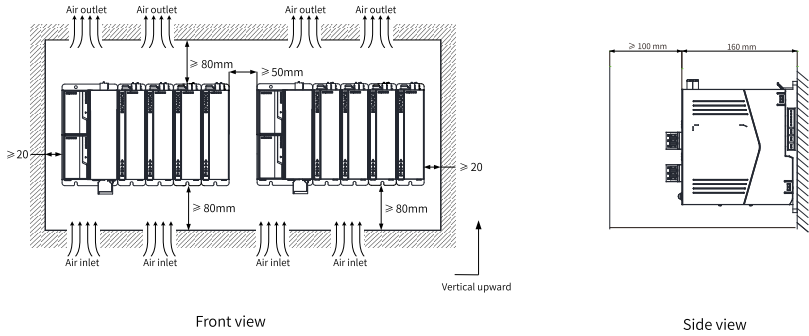

Figure 2-7 Installation clearance (side-by-side installation)

- When multiple units are installed in various racks, the minimum distance between two racks is 200 mm.

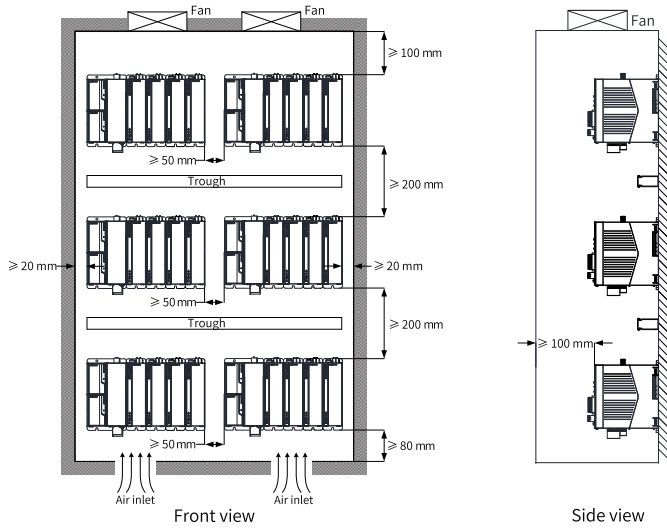

Figure 2-8 Installation clearance (multiple rack installation)

Note

Install the fan in the correct air exhaust direction to ensure that air flows from inside to outside of the cabinet. Otherwise, hot air cannot be exhausted and the drive may be overheated or damaged.

2.4 Cooling Requirements

Cabinet Door Sheet Cooling Design

The MD800 is forcibly cooled by a built-in fan. Therefore, an air inlet with an appropriate size must be opened on the cabinet door sheet to ensure that enough cooling air enters the cabinet. The air flows from bottom to top after being heated, so the cabinet air inlet must be at least 50 mm lower than the air inlet of the drive unit, as shown below.

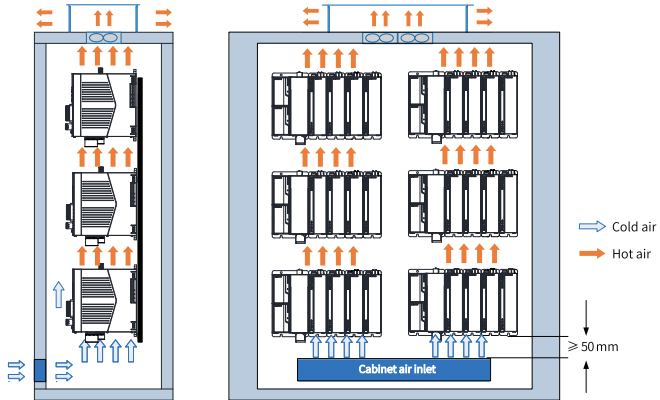

Figure 2-9 Position of the cabinet air inlet

After MD800 is mounted to the cabinet, the minimum ventilation area of the air inlet is as follows.

Table 2-1 Minimum ventilation area of the air inlet for the power supply unit or drive unit (three-phase 380-480 V)

Unit Type	Power (kW)	Quantity	Minimum Ventilation Area of the Cabinet Air Inlet (cm ²) ^{Note}
Drive unit (single-axis)	0.4	1	11.5
	0.75	1	11.5
	1.5	1	11.5
	2.2	1	11.5
	3.7	1	11.5
	5.5	1	11.5
	7.5	1	11.5
Drive unit (dual-axis)	0.4	1	11.5
	0.75	1	11.5
	1.5	1	11.5
	2.2	1	11.5
	3.7	1	11.5
Power supply unit	3.7	1	34.5
	7.5	1	34.5
	15	1	34.5

Table 2-2 Minimum ventilation area of the air inlet for the power supply unit or drive unit (single-phase 200-240 V)

Unit Type	Power (kW)	Quantity	Minimum Ventilation Area of the Cabinet Air Inlet (cm ²) ^{Note}
Drive unit (single-axis)	0.2	1	11.5
	0.4	1	11.5
	0.75	1	11.5
	1.5	1	11.5
	2.2	1	11.5
Drive unit (dual-axis)	0.2	1	11.5
	0.4	1	11.5
	0.75	1	11.5
	1.5	1	11.5
	2.2	1	11.5
Power supply unit	2.2	1	34.5
	3.7	1	34.5

Note: The ventilation area refers to the actual ventilation area, not the area of the air inlet.

For example, in the plate shown in the following figure, the size of each hole is $C \times C$ and there are 9 holes, then the actual ventilation area of the air inlet is $9 \times C \times C$.

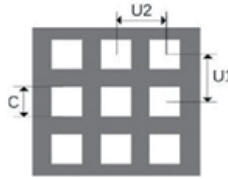

The preceding tables apply to only a single unit. When multiple units are installed in the cabinet, the total area of required ventilation area is the sum of all the above-mentioned ventilation areas.

For example, if a cabinet contains:

Power supply unit (15 kW) + Single-axis drive unit (5.5 kW) + Dual-axis drive unit (1.1 kW) + Dual-axis drive unit (1.1 kW) + Single-axis drive unit (0.4 kW),

the minimum ventilation area is $34.5 + 11.5 + 11.5 \times 2 + 11.5 = 80.5 \text{ cm}^2$. If an air filter is installed at the inlet, the air inlet resistance will rise significantly and the ventilation area must be increased to 1.2 to 1.5 times the values indicated in the tables. The ventilation areas indicated in the preceding tables are actual through-hole areas in the hole zone. Ventilation area = Area of the hole zone x Hole ratio.

Exhaust Air Design on the Top of Cabinet

Hot air within the cabinet must be exhausted to the outside to ensure sufficient cooling of the drive unit. The active air exhaust mode can be adopted for the cabinet.

Table 2-3 Minimum ventilation area of the air outlet for the power supply unit or drive unit (three-phase 380–480 V)

Unit Type	Power (kW)	Quantity	Minimum Ventilation Area of the Cabinet Air Outlet (cm ²) ^{Note}
Drive unit (single-axis)	0.4	1	18.4
	0.75	1	18.4
	1.5	1	18.4
	2.2	1	18.4
	3.7	1	18.4
	5.5	1	18.4
	7.5	1	18.4
Drive unit (dual-axis)	0.4	1	18.4
	0.75	1	18.4
	1.5	1	18.4
	2.2	1	18.4
	3.7	1	18.4
Power supply unit	3.7	1	55.2
	7.5	1	55.2
	15	1	55.2

Table 2-4 Minimum ventilation area of the air outlet for the power supply unit or drive unit (single-phase 200-240 V)

Unit Type	Power (kW)	Quantity	Minimum Ventilation Area of the Cabinet Air Outlet (cm ²) ^{Note}
Drive unit (single-axis)	0.2	1	18.4
	0.4	1	18.4
	0.75	1	18.4
	1.5	1	18.4
	2.2	1	18.4
Drive unit (dual-axis)	0.2	1	18.4
	0.4	1	18.4
	0.75	1	18.4
	1.5	1	18.4
	2.2	1	18.4
Power supply unit	2.2	1	55.2
	3.7	1	55.2

Note: The ventilation area refers to the actual ventilation area, not the area of the air outlet.

For example, in the plate shown in the following figure, the size of each hole is $C \times C$ and there are 9 holes, then the actual ventilation area of the air inlet is $9 \times C \times C$.

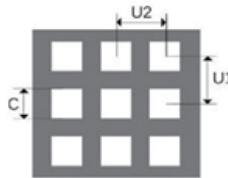

The preceding tables apply to only a single unit. When multiple units are installed in the cabinet, the total area of required ventilation area is the sum of all the above-mentioned ventilation areas. If an air filter is installed at the outlet, the air outlet resistance will rise significantly and the ventilation area must be increased to 1.2 to 1.5 times the values indicated in the tables. The ventilation areas indicated in the preceding tables are actual through-hole areas in the hole zone. Ventilation area = Area of the hole zone \times Hole ratio.

For example, if a cabinet contains:

Power supply unit (15 kW) + Single-axis drive unit (5.5 kW) + Dual-axis drive unit (1.1 kW) + Dual-axis drive unit (1.1 kW) + Single-axis drive unit (0.4 kW),

the minimum ventilation area is $55.2 + 18.4 + 18.4 \times 2 + 18.4 = 128.8 \text{ cm}^2$. In the active air exhaust mode, a fan is installed on the top of the cabinet to exhaust hot air to outside of the cabinet. Active air exhaust is a commonly used ventilation mode. To

ensure that the hot air can be exhausted to the outside, the total air volume of the fan cannot be smaller than the air volume of all units in the cabinet. The cooling air volumes required by MD800 are as follows.

Table 2-5 Cooling air volumes for the power supply units and drive units (three-phase 380-480 V)

Unit Type	Power (kW)	Quantity	Maximum Cooling Air Volume Qmax (CFM) ^{Note}
Drive unit (single-axis)	0.4	1	0
	0.75	1	8
	1.5	1	8
	2.2	1	8
	3.7	1	18
	5.5	1	19.1
	7.5	1	26
Drive unit (dual-axis)	0.4	1	8
	0.75	1	8
	1.5	1	12
	2.2	1	18
	3.7	1	26
Power supply unit	3.7	1	32
	7.5	1	60
	15	1	60

Table 2-6 Cooling air volumes for the power supply units and drive units (single-phase 200-240 V)

Unit Type	Power (kW)	Quantity	Maximum Cooling Air Volume Qmax (CFM) ^{Note}
Drive unit (single-axis)	0.2	1	0.0
	0.4	1	8.0
	0.75	1	8.0
	1.5	1	8.0
	2.2	1	20.0
Drive unit (dual-axis)	0.2	1	8.0
	0.4	1	8.0
	0.75	1	14
	1.5	1	14
Power supply unit	2.2	1	26
	3.7	1	50
			60

Note: The maximum air volume Q_{max} of the fan is the maximum value of the intersection of the P-Q curves of the fan at the abscissa, as shown in the following figure.

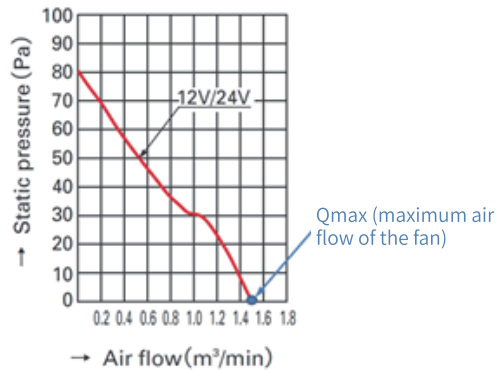

The preceding tables apply to only a single unit. When multiple units are installed in the cabinet, the total air volume of the cabinet is the sum of all the above-mentioned air volume.

For example, if a cabinet contains:

Power supply unit (15 kW) + Single-axis drive unit (7.5 kW) + Dual-axis drive unit (2.2 kW) + Dual-axis drive unit (0.75 kW),

the required minimum air volume is $60 + 26 + 18 + 8 = 112$ CFM.

Cabinet Fan Selection

Cabinet fan selection procedure:

1. Calculate the sum of cooling air flows required for all modules according to "Table 2-5" on page 40 and "Table 2-6" on page 40.
2. Determine the maximum air volume (Q_{max}) of the cabinet fan.
3. Determine the fan specifications and quantity according to the maximum air volume (Q_{max}).

Note that:

Maximum air volume of the cabinet = (1.3 to 1.5 times) the sum of cooling air volume

Maximum air volume of the cabinet = (1.6 to 2.2 times) the sum of cooling air volume (if the components such as dry nets and shutters are installed at the cabinet air outlet)

Note

- The air volume of the selected fan cannot be smaller than the maximum air volume Q_{max} . If a single fan cannot meet this requirement, multiple fans can be used.
 - Install the fan in the correct air exhaust direction to ensure that air flows from inside to outside of the cabinet. Otherwise, hot air cannot be exhausted and the drive may be overheated or damaged.
-

3 Electrical Design

3.1 Main Circuit Wiring

3.1.1 Main Circuit Terminals

Terminal Arrangement of the Power Supply Unit

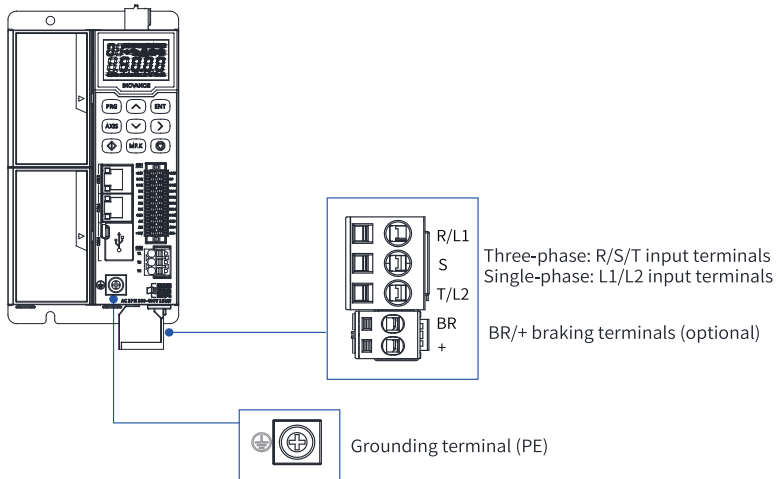



Table 3-1 Main circuit terminal description of the power supply unit

Terminal Code	Terminal Name	Function Description
R, S, and T	Three-phase power supply input terminals	Used to connect the three-phase AC input power supply.
L1, L2	Single-phase power input terminals	Used to connect the single-phase AC input power supply.
BR, +	Braking resistor connection terminals	Used to connect the braking resistor.
	Grounding (PE) terminal	Used for protective grounding.

Terminal Arrangement of the Drive Unit (Single-axis)

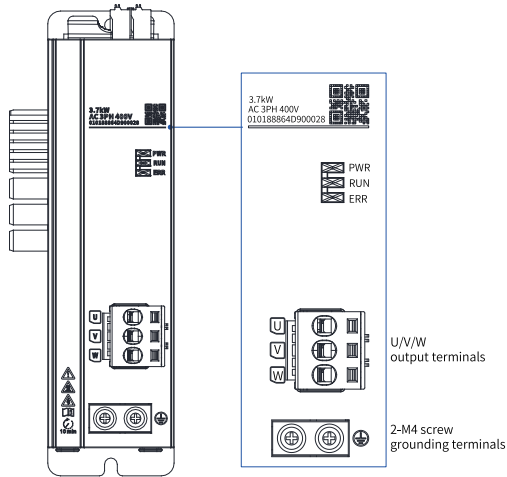

Table 3-2 Main circuit terminal description of the drive unit (single-axis)

Terminal Code	Terminal Name	Function Description
U, V, W (single-axis drive unit)	Device output terminals	Used to connect a three-phase motor.
	Grounding (PE) terminal	Used for protective grounding.

Table 3-3 Indicators of the drive unit (single-axis)

Indicator Code	Indicator Name	Status Description
PWR (yellow)	Power indicator	Steady ON: powered on OFF: powered off
RUN (green)	Running indicator	Steady ON: running OFF: stopped Blinking: operated by the operating panel of the power supply unit
ERR (red)	Alarm indicator	Steady ON: faulty OFF: normal Blinking: alarm

Terminal Arrangement of the Drive Unit (Dual-axis)

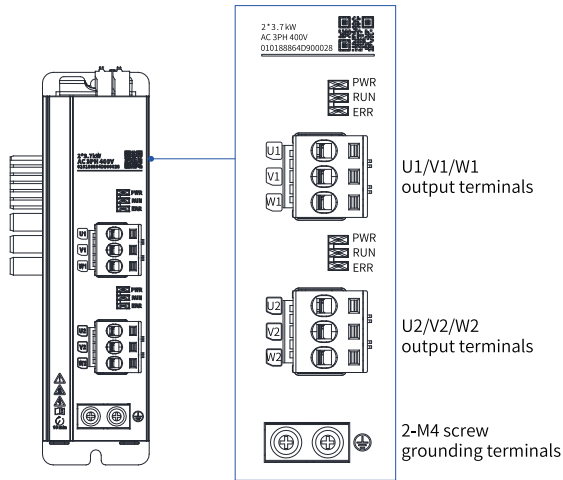

Table 3-4 Main circuit terminal description of the drive unit (dual-axis)

Terminal Code	Terminal Name	Function Description
U1, V1, W1/U2, V2, W2	Device output terminals	Used to connect a three-phase motor.
	Grounding (PE) terminal	Used for protective grounding.

Table 3-5 Indicators of the drive unit (dual-axis)

Indicator Code	Indicator Name	Status Description
PWR (yellow)	Power indicator	Steady ON: powered on OFF: powered off
RUN (green)	Running indicator	Steady ON: running OFF: stopped Blinking: operated by the operating panel of the power supply unit
ERR (red)	Alarm indicator	Steady ON: faulty OFF: normal Blinking: alarm

Terminal Arrangement of the Filter Unit

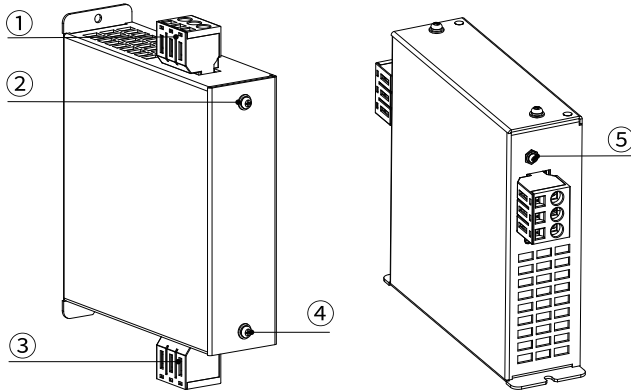

Table 3-6 Terminal description of the filter unit

No.	Terminal Name	Function Description
1	R/L1, S, T/L2 input terminals	Used for power input.
2	Input M4 grounding screw	Used for input grounding.
3	R'/L1', S', T'/L2' output terminals	Used to connect the power supply unit.
4	Output M4 grounding screw	Used for output grounding.
5	Optional EMC screw	Used for EMC grounding (optional).

3.1.2 Main Circuit Wiring Requirements

Main Circuit Wiring Requirements

- Terminals BR and (+) are used to connect options. Do not connect them to the AC power supply.
- The wire for the braking unit cannot exceed 10 m. Use the twisted pair wire or tight pair wires for parallel connection.
- Do not connect the braking resistor directly to the DC bus. Otherwise, the device may be damaged and even a fire may occur.
- The specifications and installation method of main circuit cables must comply with local regulations and related IEC requirements. Use copper conductors of a proper size as main circuit cables according to the recommended values of main circuit cable selection in this user guide.
- To protect the main circuit, separate it from the possible contact surface and provide covers as required.

- The output side cannot be connected to a capacitor or surge protection device. Otherwise, the device will frequently activate the protection mechanism or even be damaged.
- If the motor cable is too long, electrical resonance may be generated due to the impact of the distributed capacitor. The electrical resonance will lead to damage to motor insulation or high leakage current, and trigger the overcurrent protection of drive. When the motor cable is longer than 150 m, install an AC output reactor close to the drive.
- The control circuit is a safety extra-low voltage (SELV) circuit, which must be insulated and isolated from other circuits. Make sure that the control circuit is connected to the SELV circuit.
- Note that no foreign matter enters the wiring part of the terminal block.
- Do not carry out welding treatment when using stranded wires.
- The tightening torque of each terminal may be different. Tighten the screws according to the specified tightening torque using a torque screwdriver, ratchet, or wrench. If an electric tool is used to tighten the terminal screws, use a low speed setting to avoid damage to the terminal screws. Do not tighten the terminal screws at an angle of more than 5 degrees. Otherwise the terminal screws may be damaged.

Main Circuit Wiring Requirements

The power input cable of the AC drive and motor cable will generate strong electromagnetic interference. To avoid electromagnetic interference caused by long-distance parallel coupling between strong interference cable and control circuit, the distance between the main circuit cables and signal cables must be greater than 30 cm. Common main circuit cables include input R/S/T cables, output U/V/W cables, DC bus and brake cables. Signal cables include I/O signal cables, communication cables, and encoder cables.

Cable ducts must be in good connection and well grounded. Aluminum ducts can be used to ensure the electric potential of the equipment. The filter, motor, and drive must be connected to the system (machinery or appliance) properly, with coating protection at installation part and conductive metal in full contact.

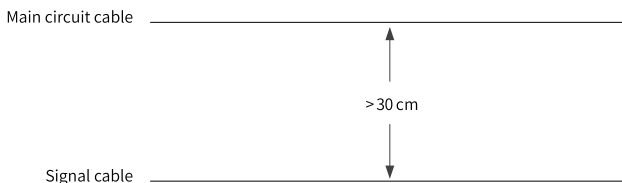

Figure 3-1 Cabling

Motor Cable Length Requirements

During operation of the AC drive, large dU/dt is generated on the output side due to the fast on-off of the power switching tube. When the motor cable is too long, a large voltage stress will be generated on the motor winding, causing insulation breakdown. It is highly recommended to use motors that comply with IEC60034-25 IVIC B or use motors with high insulation withstand voltage. In addition, with the increase of cable length, the distributed capacitance of the cable increases linearly, which is easy to generate higher harmonic current.

When the length of the motor cable is greater than the maximum length recommended in the following table, install an output reactor on the output side of the drive, or use a motor conforming to IEC60034-25 IVIC B. The output reactor can reduce the voltage stress on the motor winding.

Table 3-7 Output Reactor Cable Length and Motor Type

AC Drive Rated Power (kW)	Maximum Cable Length for Common Asynchronous Motor (m)	IEC60034-25 IVIC B Compliant	Common asynchronous induction motor
0.4 to 3.7	150 m	Not required	Required
5.5	150 m	Not required	Required
7.5	150 m	Not required	Required

Motor Output Cable Requirements

Perform the following operations to make the motor output cable. (Take MD800 dual-axis drive unit as an example.)

- Strip the cable rubber jacket and shielding layer according to the following length requirements.

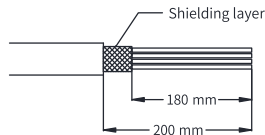

Cable connecting U1/V1/W1

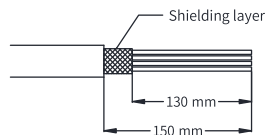

Cable connecting U2/V2/W2

- Turn the shielding layer outward or wrap it three turns with conductive tape.

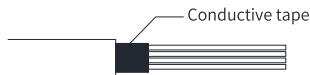

3. Make lugs for U/V/W and grounding wire according to the following length requirements.

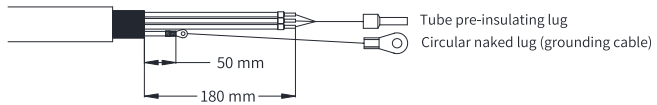

Cable connecting U1/V1/W1

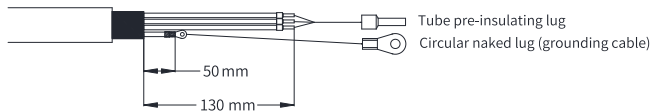

Cable connecting U2/V2/W

3.1.3 Lug Selection

It is recommended to use the lugs produced by Zhejiang KISE Terminal Co., Ltd., including tube pre-insulating lugs (TG-JT type) and circular naked lugs (TO Type).

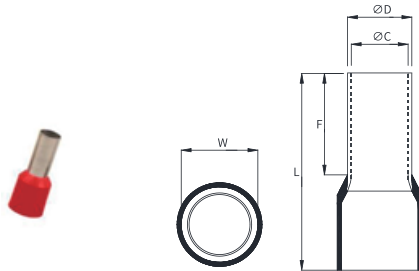

Figure 3-2 Appearance and dimensions of the tube pre-insulating lug (TG-JT type)

Table 3-8 Specifications and dimensions of the tube pre-insulating lugs (TG-JT type)

Cable Section	Model	Dimensions (mm)					Insulating Casing Color (1) For Germany (2) For France	Crimp Tool
		F	L	W	D ϕ	C ϕ		
A.W.G.22 0.5 mm ²	E0512	12	18	2.7	1.3	1	(1) Orange (2) White	OPT AN-04WF
A.W.G.20 0.75 mm ²	E7512	12	18	2.8	1.5	1.2	(1) White (2) Blue	OPT AN-04WF
A.W.G.18 1.0 mm ²	E1012	12	18.5	2.9	1.7	1.4	(1) Yellow (2) Red	OPT AN-04WF

Cable Section	Model	Dimensions (mm)					Insulating Casing Color (1) For Germany (2) For France	Crimp Tool
		F	L	W	D ϕ	C ϕ		
A.W.G.16 1.5 mm ²	E1512	12	18.5	3.5	2	1.7	(1) Red (2) Black	OPT AN-04WF
A.W.G.14 2.5 mm ²	E2512	12	19.5	4.1	2.6	2.3	(1) Blue (2) Gray	OPT AN-04WF
A.W.G.12 4.0 mm ²	E4012	12	19.5	4.5	3.15	2.8	(1) Gray (2) Orange	OPT AN-10WF
A.W.G.10 6.0 mm ²	E6012	12	20	6.4	3.85	3.5	(1) Black (2) Green	OPT AN-10WF
A.W.G.8 10 mm ²	E10-12	12	22.5	7.7	5.05	4.7	(1) Milk white (2) Brown	OPT AN-16WF

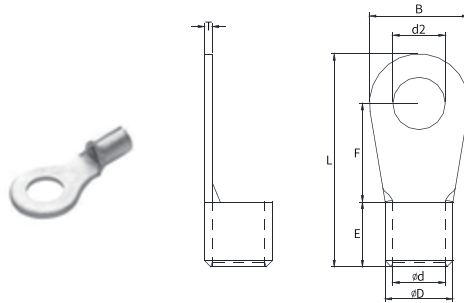

Figure 3-3 Appearance and dimensions of the circular naked lugs (TO Type)

Table 3-9 Specifications and dimensions of the circular naked lugs (TO Type)

Cable Section	Model	Dimensions (mm)								Crimp Tool
		d2	B	F	L	E	D	d	T	
A.W.G.22-16 0.5-1.5 mm ²	RNBS 1.25-4	4.3	6.5	6	14.5	5	3.5	2	0.75	IZUMI 5N18
A.W.G.16-14 1.5-2.5 mm ²	RNBS 2-4	4.3	6.5	6	14.5	5	4	2.5	0.8	IZUMI 5N18
A.W.G.14-12 2.5-4 mm ²	RNB 3.5-4	4.3	8	8	18	6	5	3	1	IZUMI 5N18
A.W.G.12-10 4-6 mm ²	RNBS 5.5-4	4.3	7	6	16.5	7	5.5	3.5	1	IZUMI 5N18
A.W.G.8 8 mm ²	RNB 8-4	4.3	8.8	10.5	23.5	8.5	7	5	1.2	IZUMI 5N18
A.W.G.6 14 mm ²	RNB 14-4	4.3	12	13.5	29.5	10.5	9	6	1.4	OPT TP-150D

3.1.4 Cable Selection for Main Circuit

Power Cable Selection Requirements

For the selection of power cables, follow the requirements specified by local countries or regions. The requirements for EC cable selection are as follows:

- Comply with EN 60204-1 and IEC 60364-5-52. To meet UL requirements, use 75°C copper wire that meets UL cable requirements.
- Use PVC copper wires.
- 40°C ambient temperature and 70°C cable surface temperature are required.
(Note: Contact the manufacturer when the ambient temperature exceeds 40°C.)

Note

If the recommended cables for peripheral equipment or options are not suitable for the product, contact the agent or Inovance.

The shielded cable must be used to satisfy the EMC requirements. Shielded cables are classified into the three-conductor cable and four-conductor cable, as shown in the following figure. If the conductivity of three-core cable shield is not sufficient, add an independent PE cable or use a four-conductor cable, of which one phase conductor is PE cable. To suppress radio frequency interference effectively, use coaxial copper braid as the shielding layer of cable. The braided density of cooper braid should be greater than 90% to enhance the shielding efficiency and conductivity.

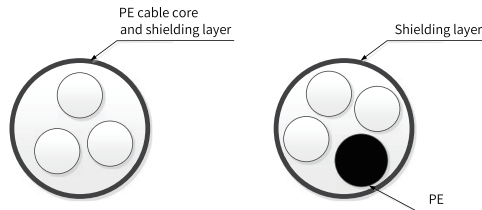

Figure 3-4 Recommended power cable types

Recommended IEC Cable Specifications for the Main Circuit

Table 3–10 Recommended IEC cable specifications for the main circuit (three-phase 380–480 V)

Category	Power (kW)	I/O terminals (RST, UVW)		Braking terminals BR, + (Optional)	
		Recommended Cable Specifications (mm ²)	Recommended Lug Specifications	Recommended Cable Specifications (mm ²)	Recommended Lug Specifications
Power supply unit	3.7	2.5	E2512	2.5	E2512
	7.5	6	E6012	4	E4012
	15	10	E10-12	6	E6012
Drive unit	0.4	0.75	E7512	-	-
	0.75	0.75	E7512	-	-
	1.5	0.75	E7512	-	-
	2.2	0.75	E7512	-	-
	3.7	1.5	E1512	-	-
	5.5	2.5	E2512	-	-
	7.5	4	E4012	-	-

Category	Power (kW)	Motor Grounding		Protective Grounding	
		Recommended Cable Specifications (mm ²)	Recommended Lug Specifications	Recommended Cable Specifications (mm ²)	Recommended Lug Specifications
Power supply unit	3.7	N/A	N/A	2.5	RNBS2-4
	7.5	N/A	N/A	6	RNBS5.5-4
	15	N/A	N/A	10	RNB14-4
Drive unit	0.4	0.75	RNBS1.25-4	Same as the protective grounding cable specifications of the power supply unit in actual applications	Same as the protective grounding lug specifications of the power supply unit in actual applications
	0.75	0.75	RNBS1.25-4	Same as the protective grounding cable specifications of the power supply unit in actual applications	Same as the protective grounding lug specifications of the power supply unit in actual applications
	1.5	0.75	RNBS1.25-4	Same as the protective grounding cable specifications of the power supply unit in actual applications	Same as the protective grounding lug specifications of the power supply unit in actual applications
	2.2	0.75	RNBS1.25-4	Same as the protective grounding cable specifications of the power supply unit in actual applications	Same as the protective grounding lug specifications of the power supply unit in actual applications
	3.7	1.5	RNBS1.25-4	Same as the protective grounding cable specifications of the power supply unit in actual applications	Same as the protective grounding lug specifications of the power supply unit in actual applications
	5.5	2.5	RNBS2-4	Same as the protective grounding cable specifications of the power supply unit in actual applications	Same as the protective grounding lug specifications of the power supply unit in actual applications
	7.5	4	RNB3.5-4	Same as the protective grounding cable specifications of the power supply unit in actual applications	Same as the protective grounding lug specifications of the power supply unit in actual applications

Table 3–11 Recommended IEC cable specifications for the main circuit (single-phase 220–240 V)

Category	Power (kW)	I/O terminals (RST, UVW)		Braking terminals BR, + (Optional)	
		Recommended Cable Specifications (mm ²)	Recommended Lug Specifications	Recommended Cable Specifications (mm ²)	Recommended Lug Specifications
Power supply unit	2.2	6	E6012	2.5	E2512
	3.7	10	E10-12	4	E4012
Drive unit	0.2	0.75	E7512	-	-
	0.4	0.75	E7512	-	-
	0.75	0.75	E7512	-	-
	1.5	1	E1012	-	-
	2.2	1.5	E1512	-	-

Category	Power (kW)	Motor Grounding		Protective Grounding	
		Recommended Cable Specifications (mm ²)	Recommended Lug Specifications	Recommended Cable Specifications (mm ²)	Recommended Lug Specifications
Power supply unit	2.2	N/A	N/A	6	RNBS5.5-4
	3.7	N/A	N/A	10	RNB14-4
Drive unit	0.2	0.75	RNBS1.25-4	Same as the protective grounding cable specifications of the power supply unit in actual applications	Same as the protective grounding lug specifications of the power supply unit in actual applications
	0.4	0.75	RNBS1.25-4	Same as the protective grounding cable specifications of the power supply unit in actual applications	Same as the protective grounding lug specifications of the power supply unit in actual applications
	0.75	0.75	RNBS1.25-4	Same as the protective grounding cable specifications of the power supply unit in actual applications	Same as the protective grounding lug specifications of the power supply unit in actual applications
	1.5	1	RNBS1.25-4	Same as the protective grounding cable specifications of the power supply unit in actual applications	Same as the protective grounding lug specifications of the power supply unit in actual applications
	2.2	1.5	RNBS1.25-4	Same as the protective grounding cable specifications of the power supply unit in actual applications	Same as the protective grounding lug specifications of the power supply unit in actual applications

Recommended NEC Cable Specifications for the Main Circuit

Table 3–12 Recommended NEC cable specifications for the main circuit (three-phase 380–480 V)

Category	Power (kW)	I/O terminals		Braking terminals BR, + (Optional)	
		Recommended Cable Specifications (AWG)	Recommended Lug Specifications	Recommended Cable Specifications (mm ²)	Recommended Lug Specifications
Power supply unit	3.7	12	E4012	14	E2512
	7.5	8	E10-12	10	E6012
	15	6	-	10	E6012
Drive unit	0.4	14	E2512	-	-
	0.75	14	E2512	-	-
	1.5	14	E2512	-	-
	2.2	14	E2512	-	-
	3.7	12	E4012	-	-
	5.5	10	E6012	-	-
	7.5	10	E6012	-	-

Category	Power (kW)	Motor Grounding		Protective Grounding	
		Recommended Cable Specifications (AWG)	Recommended Lug Specifications	Recommended Cable Specifications (AWG)	Recommended Lug Specifications
Power supply unit	3.7	N/A	N/A	12	RNB3.5-4
	7.5	N/A	N/A	8	RNB8-4
	15	N/A	N/A	6	RNB14-4
Drive unit	0.4	14	RNBS2-4	Same as the grounding cable specifications of the power supply unit in actual applications	Same as the protective grounding lug specifications of the power supply unit in actual applications
	0.75	14	RNBS2-4	Same as the grounding cable specifications of the power supply unit in actual applications	Same as the protective grounding lug specifications of the power supply unit in actual applications
	1.5	14	RNBS2-4	Same as the grounding cable specifications of the power supply unit in actual applications	Same as the protective grounding lug specifications of the power supply unit in actual applications
	2.2	14	RNBS2-4	Same as the grounding cable specifications of the power supply unit in actual applications	Same as the protective grounding lug specifications of the power supply unit in actual applications
	3.7	12	RNBS2-4	Same as the grounding cable specifications of the power supply unit in actual applications	Same as the protective grounding lug specifications of the power supply unit in actual applications
	5.5	10	RNBS5.5-4	Same as the grounding cable specifications of the power supply unit in actual applications	Same as the protective grounding lug specifications of the power supply unit in actual applications
	7.5	10	RNBS5.5-4	Same as the grounding cable specifications of the power supply unit in actual applications	Same as the protective grounding lug specifications of the power supply unit in actual applications

Note

The 6AWG cables can be directly connected to terminals without crimping lugs.

Table 3-13 Recommended NEC cable specifications for the main circuit (single-phase 220-240 V)

Category	Power (kW)	I/O terminals		Braking terminals BR, + (Optional)	
		Recommended Cable Specifications (AWG)	Recommended Lug Specifications	Recommended Cable Specifications (mm ²)	Recommended Lug Specifications
Power supply unit	2.2	8	E10-12	14	E2512
	3.7	6	-	12	E4012
Drive unit	0.2	14	E2512	-	-
	0.4	14	E2512	-	-
	0.75	14	E2512	-	-
	1.5	14	E2512	-	-
	2.2	14	E2512	-	-

Category	Power (kW)	Motor Grounding		Protective Grounding	
		Recommended Cable Specifications (AWG)	Recommended Lug Specifications	Recommended Cable Specifications (AWG)	Recommended Lug Specifications
Power supply unit	2.2	N/A	N/A	8	RNB8-4
	3.7	N/A	N/A	6	RNB14-4
Drive unit	0.2	14	RNBS2-4	Same as the grounding cable specifications of the power supply unit in actual applications	Same as the protective grounding lug specifications of the power supply unit in actual applications
	0.4	14	RNBS2-4	Same as the grounding cable specifications of the power supply unit in actual applications	Same as the protective grounding lug specifications of the power supply unit in actual applications
	0.75	14	RNBS2-4	Same as the grounding cable specifications of the power supply unit in actual applications	Same as the protective grounding lug specifications of the power supply unit in actual applications
	1.5	14	RNBS2-4	Same as the grounding cable specifications of the power supply unit in actual applications	Same as the protective grounding lug specifications of the power supply unit in actual applications
	2.2	14	RNBS2-4	Same as the grounding cable specifications of the power supply unit in actual applications	Same as the protective grounding lug specifications of the power supply unit in actual applications

Note

The 6AWG cables can be directly connected to terminals without crimping lugs.

3.2 Control Circuit Wiring

3.2.1 Control Circuit Terminals

Control Circuit Terminals of the Power Supply Unit

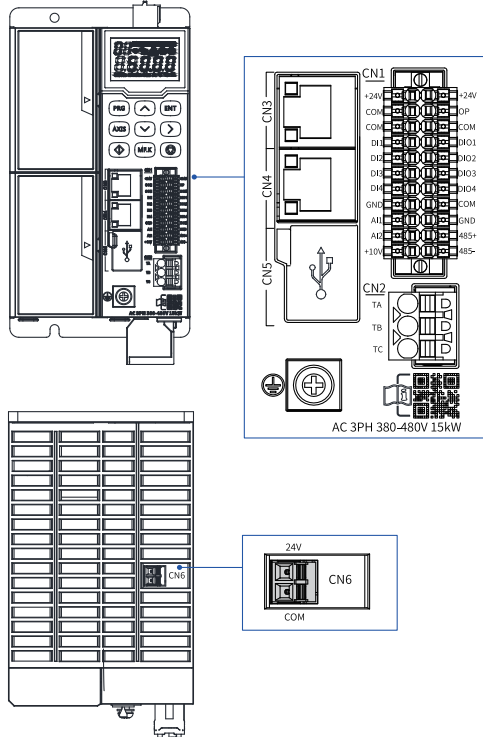
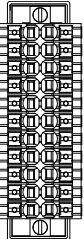

Figure 3-5 Control circuit terminal arrangement of the power supply unit

Table 3-14 Signal definitions of control terminals (CN1)

Outline Drawing	Terminal Type	Terminal Code	Terminal Function	Specifications
	+24V power output	+24V	+24V power output	Maximum output current: 100 mA
	Digital common terminal	COM	+ 24V output voltage reference terminal and digital common terminal	-
	Multi-functional input common terminal	OP	Common terminal for multi-functional input terminal	Internally isolated from COM and 24V
	+10V power output	+10V	+ 10V voltage used by analog	Maximum output current: 10 mA
	Analog common terminal	GND	Analog common terminal	-
	Analog input	AI1	Analog input	Set as voltage input, current input, or temperature input through parameters. When used as voltage/current input, AI1 and AI2 support -10 V to +10 V/0 to 20 mA. Their resolution is 12-bit, correction accuracy is 0.3%, and input impedance is 22 k Ω for voltage input and 500 Ω for current input. Temperature detection for PT100, PT1000, KTY-84-130, and PTC-130 is available.
		AI2	Analog input	

Outline Drawing	Terminal Type	Terminal Code	Terminal Function	Specifications
	Digital input	DI1	DI terminal 1	DI1 to DI4 are ordinary DIs. They do not support for high-speed pulse input. Their input frequency is lower than 100 Hz. Photocoupler isolation is supported and they are compatible with bipolar input. The input impedance is 3.3 kΩ and the effective level input voltage range is 15 V to 30 V.
		DI2	DI terminal 2	
		DI3	DI terminal 3	
		DI4	DI terminal 4	
	Digital input and output	DIO1	DI/DO terminal 1	DIO1 to DIO4 are general multifunction input/output terminals, which can be set by parameters. When they are used as DI terminals, their specifications are consistent with that of DI1 to DI4. When they are used as DO terminals, they provide the common collector open-drain output function and cannot be directly connected to the power supply. A pull-up resistor is required for connecting them to the power supply and the impedance is determined by the load requirements. The maximum output capacity is 24 VDC/50 mA.
		DIO2	DI/DO terminal 2	
		DIO3	DI/DO terminal 3	
		DIO4	DI/DO terminal 4	
	RS485 communication terminal	485+	RS485 positive communication signal	The maximum baud rate is 115200 bps. Up to 128 nodes can be connected. The Modbus communication protocol is supported. The daisy chain mode is required for wiring.
		485-	RS485 negative communication signal	
GND		Communication signal ground		

Table 3-15 Signal definitions of relay terminals (CN2)

Outline Drawing	Terminal Type	Terminal Code	Terminal Function	Specifications
	Relay output	TA	Common terminal	TA-TB: NC TA-TC: NO Contact capacity: 30 VDC/3 A 250 VAC/3 A (Cosφ = 0.4)
		TB	NC terminal	
		TC	NO terminal	

Table 3–16 Signal definitions of communication terminals and commissioning terminals (CN3, CN4, and CN5)

Outline Drawing	Terminal Type	Terminal Code	Terminal Function	Specifications
	RJ45 network terminal	CN3	<ol style="list-style-type: none"> CAN communication terminal Used to connect GP-inolink for software upgrade and commissioning 	The CANopen/CANlink communication protocol is supported. The maximum baud rate is 1 Mbps. Up to 64 nodes can be connected.
	RJ45 network terminal	CN4	<ol style="list-style-type: none"> CAN communication terminal Used to connect GP-inolink for software upgrade and commissioning Used to connect the SOP-20 operating panel for commissioning 	The maximum distance is 1000 m. The daisy chain mode is required for wiring.
	USB type C	CN5	Used to connect a computer for software upgrade and commissioning	USB 2.0 standards

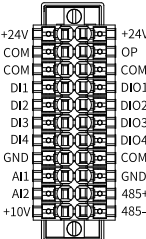
Table 3–17 Signal definitions of external 24 V input terminals (CN6)

Outline Drawing	Terminal Type	Terminal Code	Terminal Function	Specifications
	+24V power input (+)	24V	External 24 V power input	Maximum input current required: 1 A
	+24V power input (-)	COM		

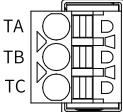
Table 3–18 Signal definitions of the DIP switch



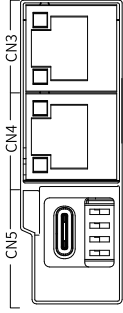

Outline Drawing	Terminal Name	Function Description	DIP Switch Position
 <p>CN5</p> <p>ON-OFF</p>	RS485 termination resistor selection	1 and 2 set to ON: termination resistor enabled	
		1 and 2 set to OFF: termination resistor disabled	
	CAN termination resistor selection	3 and 4 set to ON: termination resistor enabled	
		3 and 4 set to OFF: termination resistor disabled	

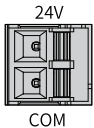
Table 3–19 Pin definitions of the CN3 terminal

Pin No.	Pin Definition	Pin Name	Terminal Pin Arrangement
1	CANH	CAN_H signal of CAN communication	
2	CANL	CAN_L signal of CAN communication	
3	CGND	CAN communication signal ground	
4	485+	RS485 communication signal+	
5	485-	RS485 communication signal-	
6	Reserved	Reserved	
7	Reserved	Reserved	
8	CGND	RS485 communication signal ground	

Table 3-20 Pin definitions of the CN4 terminal

Pin No.	Pin Definition	Pin Name	Terminal Pin Arrangement
1	CANH	CAN_H signal of CAN communication	
2	CANL	CAN_L signal of CAN communication	
3	CGND	CAN communication signal ground	
4	485+	RS485 communication signal+	
5	485-	RS485 communication signal-	
6	Reserved	Reserved	
7	15V	Power supply of the SOP-20 LCD operating panel	
8	CGND	RS485 communication signal ground	

Control Circuit Terminals of the Drive Unit (Single-axis)

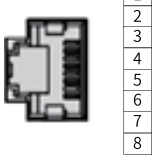
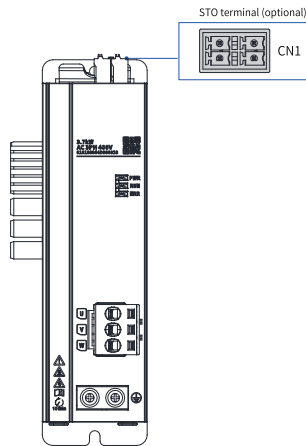
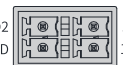

Figure 3-6 STO terminal arrangement of the drive unit (single-axis)

Table 3-21 STO terminal (optional) description of the drive unit (single-axis)

Outline Drawing	Terminal Code	Terminal Name	Specifications
	STO1	STO channel 1 power supply+	24 V input
	1GND	STO channel 1 power supply-	
	STO2	STO channel 2 power supply+	
	2GND	STO channel 2 power supply-	

Control Circuit Terminals of the Drive Unit (Dual-axis)

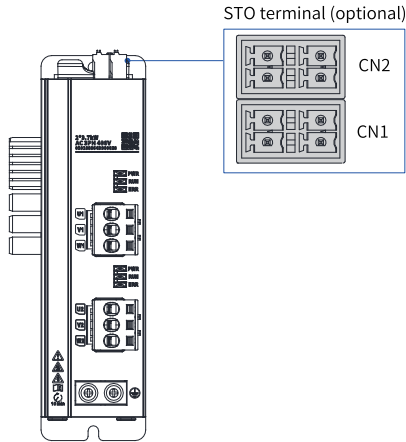

Figure 3-7 STO terminal arrangement of the drive unit (dual-axis)

Table 3-22 STO terminal (optional) description of the drive unit (dual-axis)

Outline Drawing	Terminal Code	Terminal Name	Specifications
	STO1	STO channel 1 power supply+	24 V voltage input, voltage fluctuation range $\pm 10\%$
	1GND	STO channel 1 power supply-	
	STO2	STO channel 2 power supply+	
	2GND	STO channel 2 power supply-	

3.2.2 Expansion Card Functions

Function Description of the Single-Contact Relay Output Card (IO-R1)

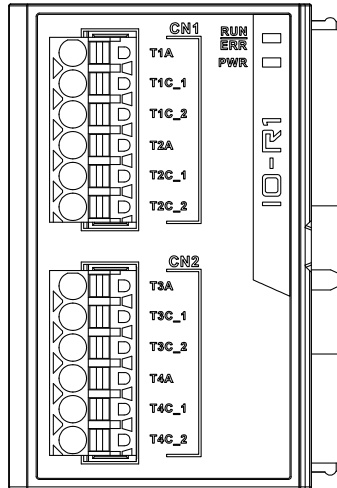

Figure 3-8 Terminal arrangement of the single-contact relay output card (IO-R1)

Table 3-23 Terminal functions of the single-contact relay output card (IO-R1)

Terminal Type	Terminal Code	Terminal Function	Specifications
CN1	T1A	Common terminal 1	TA-TC: NO Contact capacity: 30 VDC/3 A 250 VAC/3 A (Cosφ = 0.4)
	T1C_1	NO terminal 1_1	
	T1C_2	NO terminal 1_2	
	T2A	Common terminal 2	
	T2C_1	NO terminal 2_1	
	T2C_2	NO terminal 2_2	
CN2	T3A	Common terminal 3	
	T3C_1	NO terminal 3_1	
	T3C_2	NO terminal 3_2	
	T4A	Common terminal 4	
	T4C_1	NO terminal 4_1	
	T4C_2	NO terminal 4_2	

Table 3–24 Indicators of the single-contact relay output card (IO-R1)

	Indicator	State Description	Solution
RUN/ERR	Green indicator steady ON	Normal running state	N/A
	Green indicator blinking	The expansion card is in initialization state.	N/A
	Green indicator OFF	Waiting for initialization of the power supply unit	N/A
	Red indicator steady ON	Hardware fault	Replace the expansion card.
	Red indicator blinking	Data frame loss or communication disconnection with the power supply unit or drive unit	1. Check the hardware connection. 2. Check whether the power supply unit or drive unit is normal. 3. If the hardware connection, power supply unit, and drive unit are normal, replace the expansion card.
	Red and green indicators blinking alternatively	Internal communication bus in the BUSOFF state, and communication restart in progress	Replace the expansion card if the state is not recovered.
PWR	Yellow indicator steady ON	Power normal	N/A
	Yellow indicator OFF	Power supply abnormal	Replace the expansion card.

Function Description of the Dual-Contact Relay Output Card (IO-R2)

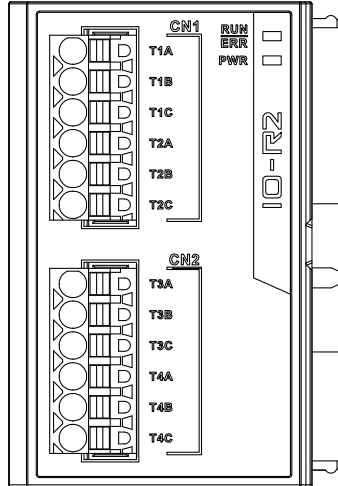

Figure 3-9 Terminal arrangement of the dual-contact relay output card (IO-R2)

Table 3-25 Terminal functions of the dual-contact relay output card (IO-R2)

Terminal Type	Terminal Code	Terminal Function	Specifications
CN1	T1A	Common terminal 1	TA-TB: NC TA-TC: NO Contact capacity: 30 VDC/3 A 250 VAC/3 A (Cosφ = 0.4)
	T1B	NC terminal 1	
	T1C	NO terminal 1	
	T2A	Common terminal 2	
	T2B	NC terminal 2	
	T2C	NO terminal 2	
CN2	T3A	Common terminal 3	
	T3B	NC terminal 3	
	T3C	NO terminal 3	
	T4A	Common terminal 4	
	T4B	NC terminal 4	
	T4C	NO terminal 4	

Table 3-26 Indicators of the dual-contact relay output card (IO-R2)

	Indicator	State Description	Solution
RUN/ERR	Green indicator steady ON	Normal running state	N/A
	Green indicator blinking	The expansion card is in initialization state.	N/A
	Green indicator OFF	Waiting for initialization of the power supply unit	N/A
	Red indicator steady ON	Hardware fault	Replace the expansion card.
	Red indicator blinking	Data frame loss or communication disconnection with the power supply unit or drive unit	1. Check the hardware connection. 2. Check whether the power supply unit or drive unit is normal. 3. If the hardware connection, power supply unit, and drive unit are normal, replace the expansion card.
	Red and green indicators blinking alternatively	Internal communication bus in the BUSOFF state, and communication restart in progress	Replace the expansion card if the state is not recovered.
PWR	Yellow indicator steady ON	Power normal	N/A
	Yellow indicator OFF	Power supply abnormal	Replace the expansion card.

Function Description of the Multi-functional Card (IO-M1)

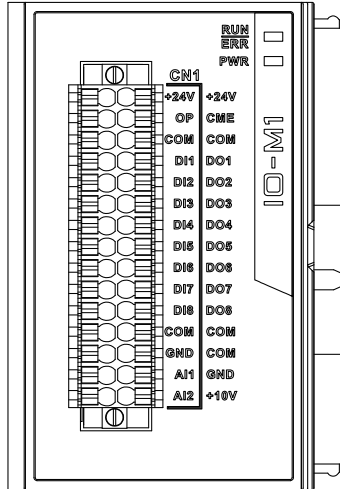

Figure 3-10 Terminal arrangement of the multi-functional card (IO-M1)

Table 3-27 Terminal functions of the multi-functional card (IO-M1)

Terminal Code	Terminal Function	Terminal Type	Specifications
+24V	24 V power supply	-	24V±10%, maximum: 100 mA
OP	Common terminal for multi-functional input terminal	-	-
CME	Multi-functional output common terminal	-	-
COM	-	-	-
DI1	DI terminal 1	Digital input	DI1 to DI8 are ordinary DIs whose response time is 10 ms. They do not support high-speed pulse input. Their input frequency is lower than 100 Hz. Photocoupler isolation is supported and they are compatible with bipolar input. Input impedance: 3.3 kΩ. Effective level input voltage range: 15–30 V
DI2	DI terminal 2		
DI3	DI terminal 3		
DI4	DI terminal 4		
DI5	DI terminal 5		
DI6	DI terminal 6		
DI7	DI terminal 7		
DI8	DI terminal 8		

Terminal Code	Terminal Function	Terminal Type	Specifications
DO1	DO terminal 1	Digital output	DO1 to DO8 are ordinary isolated sink/source output terminals, which cannot be directly connected to the power supply. A pull-up resistor is required for connecting them to the power supply and the impedance is determined by the load requirements. The maximum output capacity is 24 VDC/50 mA.
DO2	DO terminal 2		
DO3	DO terminal 3		
DO4	DO terminal 4		
DO5	DO terminal 5		
DO6	DO terminal 6		
DO7	DO terminal 7		
DO8	DO terminal 8		
AI1	AI terminal 1	Analog input	Set as voltage input, current input, or temperature input through parameters. When used as voltage/current input, AI1 and AI2 support -10 V to +10 V/0 to 20 mA. Their resolution is 12-bit, correction accuracy is 0.3%, and input impedance is 22 k Ω for voltage input and 500 Ω for current input. Temperature detection for PT100, PT1000, KTY-84-130, and PTC-130 is available.
AI2	AI terminal 2		
+10V	10V power supply	10V power supply	10 V \pm 10%, maximum 10 mA
GND	Analog ground	Analog ground	

Table 3–28 Indicators of the multi-functional card (IO-M1)

	Indicator	State Description	Solution
RUN/ERR	Green indicator steady ON	Normal running state	N/A
	Green indicator blinking	The expansion card is in initialization state.	N/A
	Green indicator OFF	Waiting for initialization of the power supply unit	N/A
	Red indicator steady ON	Hardware fault	Replace the expansion card.
	Red indicator blinking	Data frame loss or communication disconnection with the power supply unit or drive unit	<ol style="list-style-type: none"> 1. Check the hardware connection. 2. Check whether the power supply unit or drive unit is normal. 3. If the hardware connection, power supply unit, and drive unit are normal, replace the expansion card.
	Red and green indicators blinking alternatively	Internal communication bus in the BUSOFF state, and communication restart in progress	Replace the expansion card if the state is not recovered.
PWR	Yellow indicator steady ON	Power normal	N/A
	Yellow indicator OFF	Power supply abnormal	Replace the expansion card.

Function Description of the EtherCAT Communication Card (SI-ECAT)

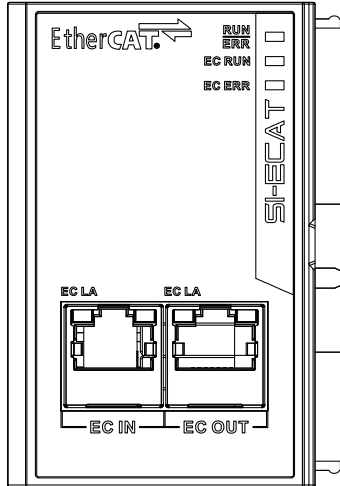

Figure 3-11 Terminal arrangement of the EtherCAT communication card (SI-ECAT)

The EtherCAT communication expansion card (SI-ECAT) is connected to the EtherCAT master station using the standard Ethernet RJ45 socket. Its pin signal definitions are the same as those of the standard Ethernet pins. They can be connected using crossover cables or straight-through cables.

Table 3-29 Terminal functions of the EtherCAT communication expansion card (SI-ECAT)

Terminal Code	Terminal Name	Description
EC IN	Input terminal	After installation, EC IN is on the left and ECAT OUT is on the right when facing to the RJ45 interface. The two interfaces must be connected correctly. The Cat5e shielded twisted pair (STP) network cable must be used for ensuring stability. To improve the anti-interference capability of communication, it is recommended to install it in the expansion card slot 2.
EC OUT	Output terminal	

Table 3-30 Indicators of the EtherCAT communication expansion card (SI-ECAT)

Indicator		State Description	Solution
RUN/ERR	Green indicator steady ON	Communication normal	N/A
	Red indicator steady ON	ECAT card and node communication timeout	Check the connector for interference.
	Red indicator blinking slowly	ECAT card and power supply unit communication timeout	1. Check that the communication card is installed correctly. 2. Check whether the power supply unit is normal.
	Red indicator blinking quickly	ECAT card faulty	Troubleshoot the fault according to the fault code displayed on the operating panel of the power supply unit.
EC RUN	Green indicator blinking slowly	EtherCAT state machine status: disconnection	N/A
	Green indicator OFF	EtherCAT state machine status: INIT = initializing	N/A
	Green indicator blinking quickly	EtherCAT state machine status: PREOP = pre-operational	N/A
	Green indicator blinking once	EtherCAT state machine status: SAFEOP = safe operation	N/A
	Green indicator steady ON	EtherCAT state machine status: OP = operating	N/A
EC ERR	Red indicator OFF	EtherCAT communication normal	N/A
	Red indicator steady ON	EtherCAT communicate faulty	Check the fault code on the operating panel of the power supply unit.

Indicator		State Description	Solution
EC LA	Yellow indicator OFF	No connection with the previous EtherCAT device	N/A
	Yellow indicator steady ON	Connected with the previous EtherCAT device	N/A
	Green indicator OFF	No data exchange with the network interface	N/A
	Green indicator blinking	Data exchange with the network interface	N/A

Function Description of the PROFINET Communication Expansion Card (SI-PN)

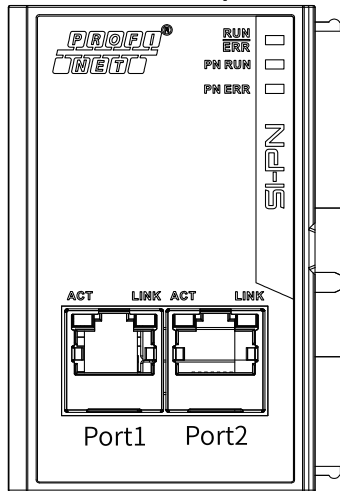

Figure 3-12 Terminal arrangement of the PROFINET communication expansion card (SI-PN)

The PROFINET communication expansion card (SI-PN) is connected to the PROFINET master station using the standard Ethernet RJ45 socket. Its pin signal definitions are the same as those of the standard Ethernet pins. They can be connected using crossover cables or straight-through cables.

Table 3-31 Terminal functions of the PROFINET communication expansion card (SI-PN)

Terminal Code	Terminal Name	Description
Port1	Network port Port1	Connection terminals (Port1 for input and Port2 for output) After installation, Port1 is on the left and Port2 is on the right when facing to the RJ45 interface. The Cat5e shielded twisted pair (STP) network cable is recommended for ensuring stability. To improve the anti-interference capability of communication, it is recommended to install it in the expansion card slot 2.
Port2	Network port Port2	

Table 3-32 Indicators of the PROFINET communication expansion card (SI-PN)

	Indicator	State Description	Solution
RUN/ERR	Green indicator steady ON	Communication normal	N/A
	Red indicator steady ON	PROFINET expansion card and node communication timeout	1. Restart the PROFINET card. 2. Eliminate field interference.
	Red indicator blinking quickly (500 ms)	PROFINET expansion card internal communication timeout	
	Red indicator blinking slowly (1s)	PROFINET expansion card and power supply unit timeout	
PN RUN	Steady ON	PROFINET expansion card communication normal	N/A
PN ERR	Steady ON	Communication with the master station interrupted	Check the wiring.
	Blinking	Blinking request sent by master station	N/A

3.2.3 Wiring Description of Control Circuit Terminals

Wiring of Analog Input Terminals (AI1-AI2)

Weak analog voltage signals are prone to suffer external interference. Therefore, the shielded cable shorter than 20 m is required. In applications where the analog signal suffers severe interference, install a filter capacitor or ferrite core at the analog signal source.

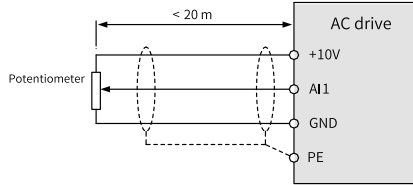

Figure 3-13 Wiring of AI terminals

Wiring of Digital Input Terminals (DI1-DI4)

The DI terminals can be wired in the sink (NPN) and source (PNP) mode.

- Sink wiring mode
 - Using the internal 24 V power supply of the AC drive is the most commonly used wiring mode. In this mode, the OP terminal and 24 V terminal of the AC drive are shorted, and the COM terminal is connected to the 0V terminal of the external controller, as shown in the following figure.

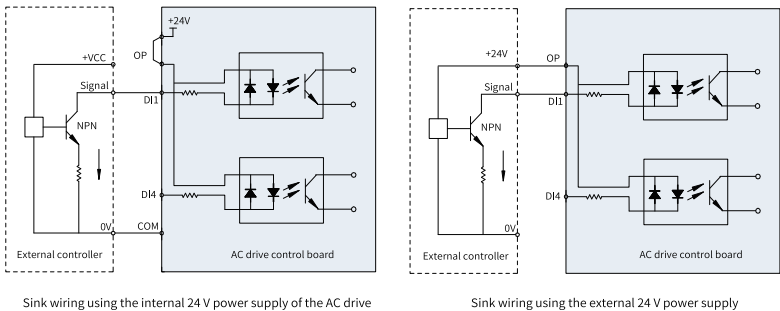

Figure 3-14 Sink wiring mode

- If an external 24 V power supply is used, the jumper between the +24 V and the OP terminals must be removed, the 24 V positive electrode of the external power supply must be connected to the OP terminal, and the 0 V terminal of the external power supply must be connected to a corresponding DI terminal through the controller contact. See the following figure.

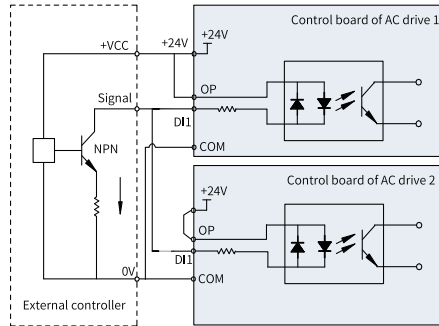

Figure 3-15 Parallel connection of DI terminals (multiple AC drives) in sink mode

- Source wiring mode
 - If the 24 V internal power supply of the AC drive is used, the jumper between the + 24V and the OP terminals must be removed, the OP and the COM terminals must be connected, and the + 24V terminal and the common terminal of the external controller must be connected, as shown in the following figure.
 - If an external power supply is used, the jumper between the +24 V and the OP terminals must be removed, the 0V terminal of the external power supply must be connected to the OP terminal, and the 24V positive electrode of the external power supply must be connected to a corresponding DI terminal through the external controller contact.

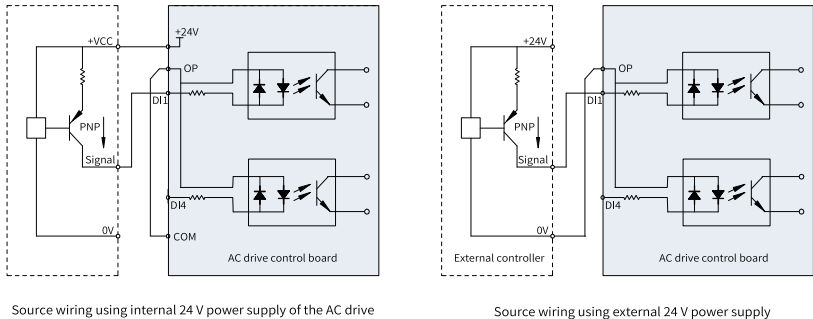

Figure 3-16 Source wiring mode

Wiring of Digital Input/Output Terminals (DIO1–DIO4)

DIO1 to DIO4 can be used as DI or DO terminals, which can be set by F4-41. They are used as DI terminals by default and cannot be used as both DI terminals and DO terminals at the same time.

When they are used as DI terminals, their wiring mode is consistent with that of DI1 to DI4. When they are used as DO terminals, the DO common terminal is COM and only the sink wiring mode is supported, as shown in the following figure. In this case, it is recommended that the DI common terminal OP be connected to the 24V terminal. If the OP terminal is connected to the COM terminal, the customer's device may receive input signals before signals are output through the DIO terminal.

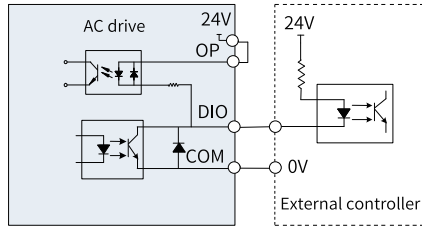

Figure 3-17 Wiring of DIO terminals used as DO terminals

Wiring of Relay Output Terminals

The inductive load (relay, contactor, and motor) causes voltage spike after the current is removed. A voltage dependent resistor (VDR) must be used for protection at the relay contact and absorption circuits such as VDRs, RC absorption circuits and diodes must be installed on inductive loads to ensure minimum interference during cutoff.

When a contactor and an intermediate relay are connected to 220 VAC, a VDR with a withstand voltage higher than 275 VAC must be paralleled at both ends of the drive coil of the contactor and intermediate relay. When a contactor and an intermediate relay are connected to 24 VDC, a freewheel diode must be inversely paralleled at both ends of the drive coil of the contactor and intermediate relay, that is, the cathode and anode of the freewheel diode are connected to the 24 V side and non-24 V side of the drive coil respectively.

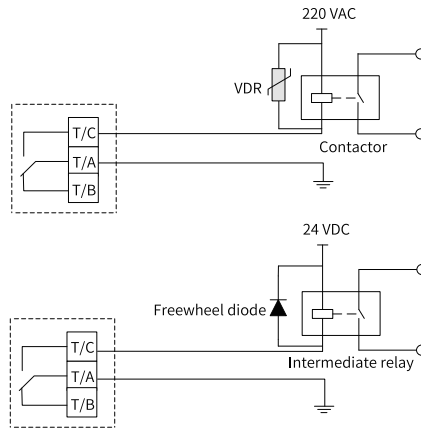

Figure 3-18 Anti-interference processing of relay output terminals

Note

- If relay output terminals are connected to 220 V dangerous voltage, pay attention to distinguishing them from the surrounding safety extra-low voltage circuit terminals to ensure correct connection. The requirements for reinforced insulation must be taken into consideration during wiring.
- The external 220 V power supply connected to the relay must be used in an environment with overvoltage class II (OVC II).

3.2.4 Control Circuit Wiring Requirements

Note

Wire the control circuit in accordance with EN 60204-1.

Cable Selection Requirements for the Control Circuit

To avoid the influence of strong external interference noise on the control circuit, it is recommended that the shielded cable with shielding layer be used as the signal cable. The shielding layer must be connected to the equipment in 360° with signal shielding brackets at both ends of the shielding layer. Separate shielded cables should be used for different analog signals, and shielded twisted pair (STP) cables are recommended for digital signal cables.

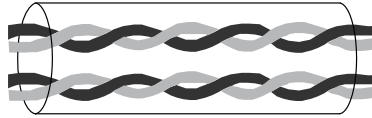

Figure 3-19 STP

Table 3-33 Recommended cable specifications for the control circuit

Category	Terminal Type	Recommended IEC Cable Specifications (mm ²)	Recommended NEC Cable Specifications (AWG)	Recommended Lug Specifications
Power supply unit and optional expansion card	Control signal terminal	0.5	22-20	IEC: 0.5 mm ² (E0512) 0.75 mm ² (E7512) 1 mm ² (E1012) 1.5 mm ² (E1512) NEC: 22 AWG (E0512) 20 AWG (E0512) 18 AWG (E1012) 16 AWG (E1512) For details about the lug specifications, see "3.1.3 Lug Selection" on page 49 <i>Lug Selection</i> .
	24 V input terminal	0.5-1.5	22-16	
	Relay terminal	0.5-1.5	22-16	
Drive unit	STO terminal (optional)	0.5	22-20	

Wiring Requirements for the I/O Signal Cables

- I/O signals include analog input (AI), analog output (AO), digital input (DI), digital output (DO) and relay output signals. Before wiring the I/O terminals, disconnect the main power supply and ensure that the danger indicator of the AC drive is off.
- To avoid interference on the I/O signals, separate the I/O signal cables at least 30 cm from the main circuit cables (three-phase R/S/T and U/V/W, or single-phase L1/L2) and other power cables (or power lines).
- To avoid malfunction of the AC drive and equipment, separate the cable connecting the relay output terminal from other I/O signal cables by more than 30 cm.

3.3 Communication Wiring

3.3.1 RS485 Communication Wiring

RS485 communication connection with PLC

Connect the RS485 bus using three-core shielded cables. Three cables are required for connecting this product to the 485+, 485-, and GND terminals. Twisted pair shielded cables must be used to connect 485+ and 485-. The twisted pair is connected to 485 +/485-, and the shielding layer is connected to GND.

Table 3–34 Pin connection relation of the communication cable between the AC drive and PLC

AC drive		PLC	
Communication Type	Signal	Communication Type	Signal
RS485	485+	RS485	485+
	485-		485-
	GND		GND

RS485 Communication Connection for Multi-drive Applications

The following tables describes the cable connection between multiple AC drives during RS485 communication networking.

Table 3–35 Pin connection relation of the communication cable for parallel connection

AC Drive (A Side)		AC Drive (B Side)	
Communication Type	Signal	Communication Type	Signal
RS485	485+	RS485	485+
	485-		485-
	GND		GND

The daisy chain mode is required for RS485 bus connection of a large number of nodes, as shown in the following figures. The RS485 signal reference ground of all nodes must be connected together. Up to 128 nodes can be connected.

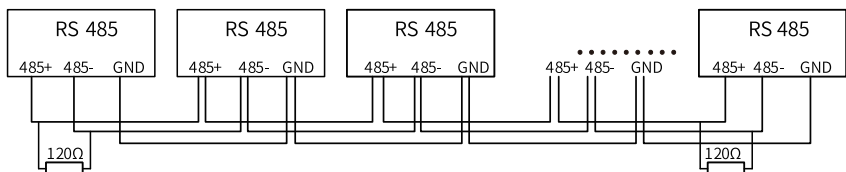

Figure 3-20 RS485 bus topology

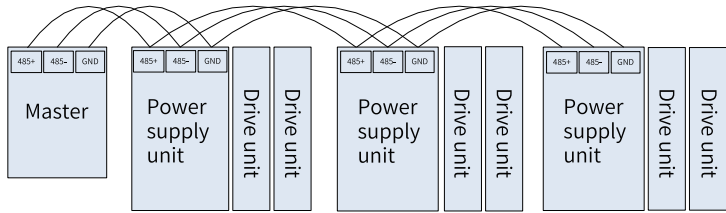

Figure 3-21 Daisy chain

Transmission Distance

The maximum number of nodes and transmission distance of standard RS485 circuit vary with the baud rate, as listed in the following table.

Table 3–36 Maximum number of nodes and transmission distance

Transmission Distance (m)	Baud Rate (kbps)	Number of Nodes	Cable Diameter
100	115.2	128	AWG26
1,000	19.2	128	AWG26

Termination Resistor Settings

Table 3–37 Termination resistor settings

Terminal Definition		Pin Description
Pin No.	Network Name	
1	DIP switch for RS485 termination resistor selection	By default, the RS485 termination resistor is disabled. To enable the RS485 termination resistor, set pins 1 and 2 to ON.
2		

3.3.2 CAN Communication Wiring

CAN Communication with the PLC

The CAN bus has two RJ45 network ports on the power supply unit. Use the Cat 5e shielded network cable and connect a 120 Ω termination resistor at both ends of the bus to prevent CAN signals from reflecting.

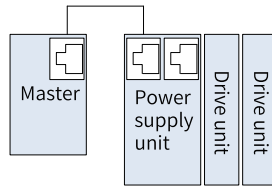

Figure 3-22 Topology of CAN communication with the PLC

CAN Communication Connection for Multi-drive Applications

Use the Cat 5e shielded network cables to connect the units in hand-in-hand mode, as shown in the following figure. A maximum of 64 nodes can be connected. To prevent CAN signals from reflecting, connect a 120 Ω termination resistor at both ends of the bus.

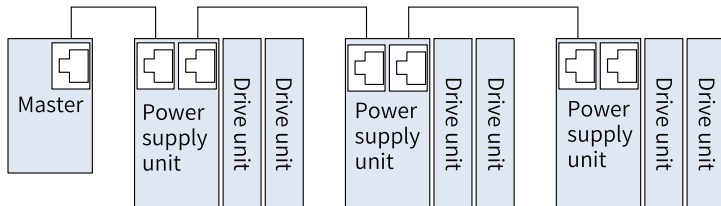

Figure 3-23 CAN bus topology

Transmission Distance

The transmission distance of CAN bus is related to the baud rate and communication cable. The relationship between the maximum transmission distance of CAN bus and the baud rate is described in the following table.

Table 3-38 Transmission distance and speed

Transmission Distance (m)	Baud Rate (kbps)	Number of Nodes
25	1,000	64
95	500	64
560	100	64
1,000	50	64

Termination Resistor Settings

Table 3-39 Termination resistor settings

Terminal Definition		Pin Description
Pin No.	Network Name	
3	DIP switch for CAN termination resistor selection	By default, the CAN termination resistor is disabled. To enable the CAN termination resistor, set pins 3 and 4 to ON,
4		

3.3.3 Ethernet Wiring

Communication Networking

The AC drive supports Ethernet bus, including PROFINET and EtherCAT. It adopts the standard RJ45 network port and standard crystal connector. The Cat 5e shielded twisted pair cable with iron shell injection molding must be used to connect with the Ethernet master station properly. With relevant communication setting, the communication with the Ethernet master station can be realized, thus realizing the networking function of the AC drive.

The topological structures supported by Ethernet include bus, star, and tree topologies. Various networking can be realized by using switches correctly.

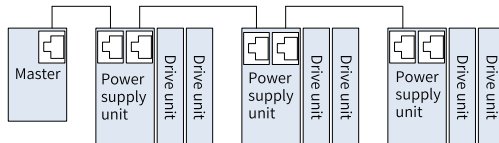

Figure 3-24 Bus topology

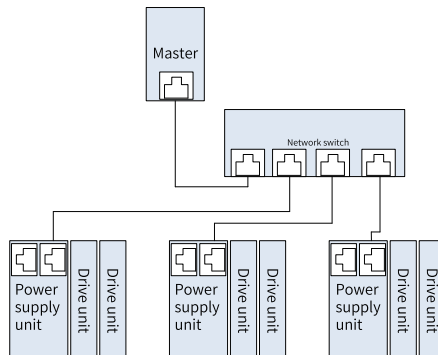

Figure 3-25 Star topology

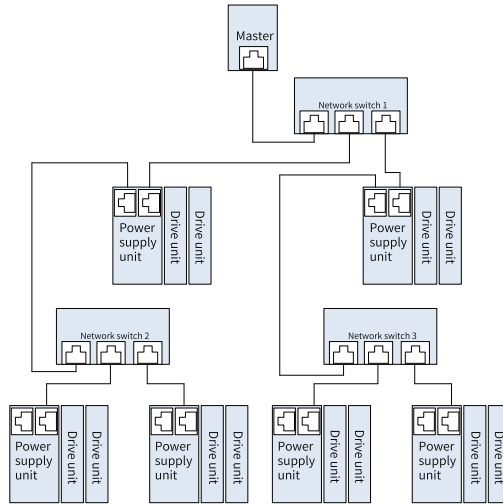

Figure 3-26 Tree topology

Cable Specifications

The Ethernet bus uses shielded cables for network data transmission. The following table lists the recommended specifications of network cables.

Table 3-40 Ethernet cable specifications

Item	Specifications
Cable type	Elastic crossover cable (8P8C straight-through cable), S-FTP, Cat 5e
Standard compliance	EIA/TIA568A, EN50173, ISO/IEC11801 EIA/TI Abulletin TSB, EIA/TIA SB40-A&TSB36
Cable section	AWG26
Cable category	Twisted pair
Pair	4



Figure 3-27 Shielded network cable

To connect the RJ45 network cable, hold the registered jack of the cable and insert it into the RJ45 interface of the communication module until it makes a "click" sound. To remove the RJ45 network cable, press and hold the tail of the registered jack, and then pull it out along the direction parallel with the module.

To avoid the influence on the communication cable due to other stresses and ensure the stability of communication, secure the cable near the equipment before Ethernet communication.

Ring topology or linear topology can be realized with the two interfaces on the AC drive. Only one interface needs to be connected at the beginning or end of the circuit. The maximum cable length allowed between two nodes is 100 m.

Note

If the communication between the equipment and the controller needs to be maintained when the main power supply is cut off, connect the external 24 V power supply through CN6 (external 24 V power supply input terminal) to supply power to the AC drive.

3.4 Grounding

3.4.1 Main Circuit Grounding Requirements



- Ground the grounding terminal to avoid electric shocks. Comply with the relevant local electrical regulations for grounding.
 - To prevent electric shocks, ensure that the protective grounding conductor meets the technical specifications and local safety standards, and shorten the grounding cable length as much as possible. The leakage current of the product will exceed 3.5 mA, so copper cables with a cross-sectional area of at least 10 mm² must be used as protective grounding conductors according to EN 61800-5-1, or two protective grounding conductors of the same specification shall be used for connection.
 - When using multiple devices, follow the instructions for grounding all devices. Incorrect equipment grounding will lead to misoperation of equipment.
-

Main circuit grounding requirements:

- Use a proper yellow-green copper wire for protective grounding conductor, and do not connect it to switches such as circuit breakers.
- The grounding terminal must be reliably grounded to ensure normal running of the equipment and avoid equipment damage.
- Do not connect the grounding terminal to the N terminal of the power supply.

- It is recommended that the equipment be installed on a conductive metal surface to ensure that the entire conductive bottom of the equipment is properly overlapped with the installation surface.
- The grounding screws must be fixed with the recommended tightening torque to avoid loose or too tight fixing of the protective grounding conductor.

3.4.2 Grounding of the Control Board

By default, the control board is grounded. When grounding is not required, remove the knockout of the EMC grounding screw hole at ①, and remove the EMC screw here with a Phillips screwdriver to disconnect the control board from grounding.

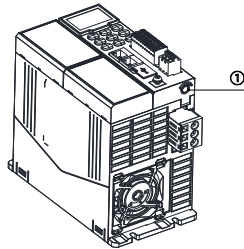

Figure 3-28 Position of the EMC grounding screw of the control board

3.4.3 Grounding of a Single Device

Each unit (power supply unit, drive unit, and filter unit) must be well grounded. The power supply unit, drive unit, input reactor, filter (or filter unit) are connected to the grounding copper busbar of the equipment cabinet in star connection mode, and the output side of the drive unit is connected to the motor, as shown in the following figure.

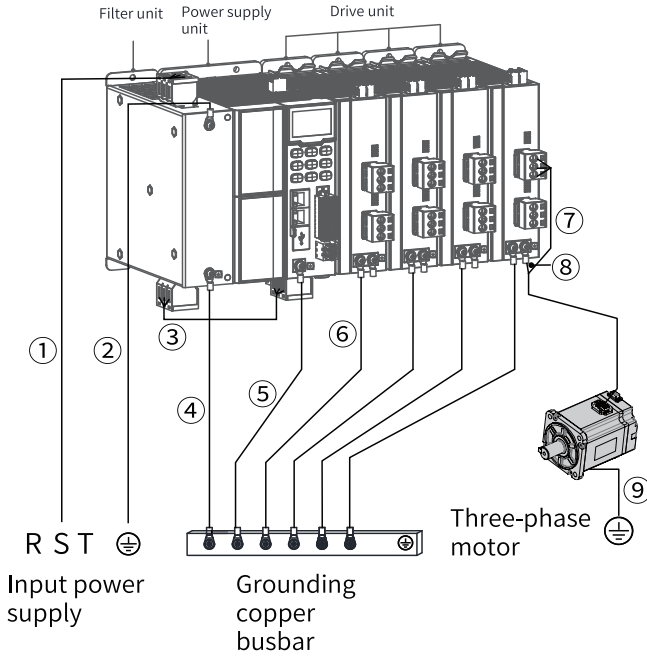

Figure 3-29 Equipment grounding

No.	Wiring Description
①	Connect the input terminals of the filter unit to the input terminals R/S/T of the power supply.
②	Connect the input M4 grounding screw of the filter unit to the power ground.
③	Connect the output terminals of the filter unit to the input terminals of the power supply unit. It is recommended to use shielded cables.
④	Connect the output M4 grounding screw of the filter unit to the grounding copper busbar.
⑤	Connect the M4 grounding screw of the power supply unit to the grounding copper busbar.
⑥	Connect the M4 grounding screw of the drive unit to the grounding copper busbar.
⑦	Connect the input terminals of the drive unit to the input terminals of the motor.
⑧	Connect the motor output grounding cable of the drive unit to the grounding screw of the drive unit.
⑨	Ground the motor enclosure.

Note

In the preceding figure, the power supply unit is equipped with four dual-axis drive units. In the figure, only axis 1 of the rightmost drive unit is taken as an example to introduce the wiring of the drive unit. The wiring for other drive units is similar.

3.4.4 Grounding of Multiple Devices

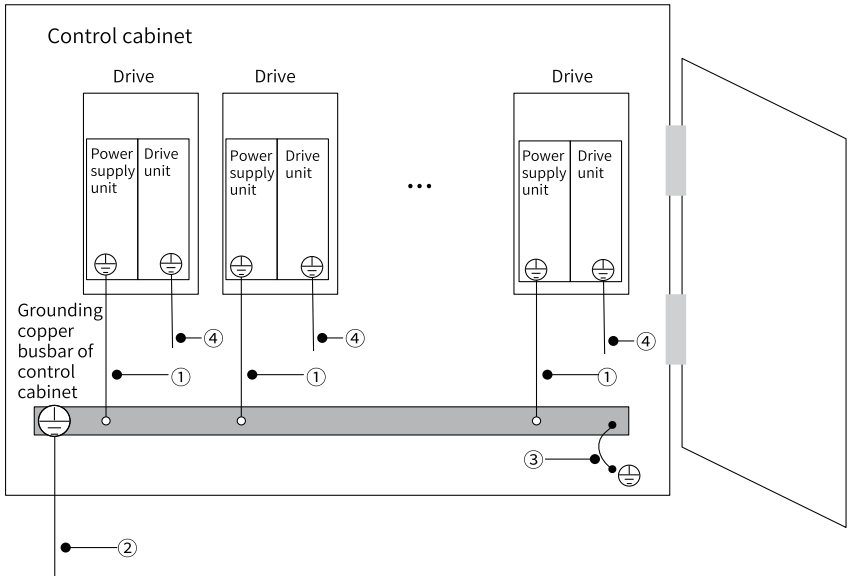

Figure 3-30 Grounding in parallel connection

Table 3-41 Grounding description for parallel connection

No.	Wiring Description
①	The main circuit input PE terminal of the product is connected to the grounding copper busbar of the control cabinet through the protective grounding conductor.
②	Connect the PE cable of the input power supply to the grounding copper busbar of the control cabinet.
③	Connect the grounding copper busbar of the control cabinet to the metal enclosure of the control cabinet through the protective grounding conductor.
④	Connect the motor output cable ground to the output PE terminal of the product.

3.4.5 Grounding of the Cabinet System

The most economical and effective measure to suppress interference in the cabinet is to isolate the interference source from the equipment that may be interfered during installation. According to the strength of interference sources, the electric cabinet must be divided into multiple EMC areas or multiple cabinets, and the equipment must be installed in the corresponding areas according to the wiring requirements in the following table.

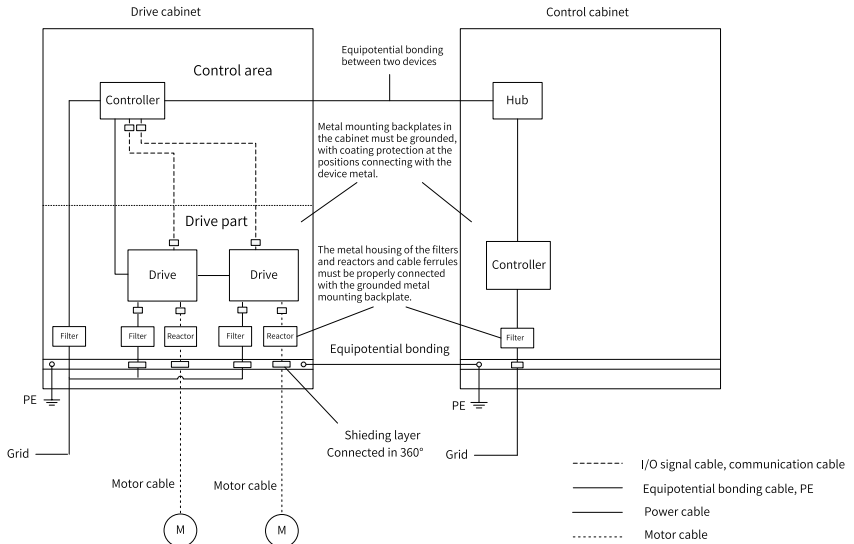

Figure 3-31 Recommended cabinet system grounding

Table 3-42 Cabinet system grounding requirements

No.	Wiring Requirements
1	Place the control equipment and the drive equipment in two separate cabinets.
2	When multiple cabinets are used, grounding cables with a cross-sectional area of at least 16 mm ² shall be used for connection between cabinets to realize equipotential between cabinets.
3	Place the equipment in different areas according to the signal strength inside the cabinet.
4	Equipotential bonding must be carried out for equipment in different areas of the cabinet.
5	All communication (for example, RS485) and signal cables leading from the electrical cabinet must be shielded.

No.	Wiring Requirements
6	The power input filter in the cabinet must be placed close to the cabinet input interface.
7	Each grounding point in the cabinet must be protected by spraying.

4 Selection of Options

4.1 Electrical Peripherals

4.1.1 Fuse, Circuit Breaker, and Contactor

To meet the requirements of European safety standard EN 61800-5-1 and North American safety standard UL61800-5-1, a fuse or circuit breaker must be connected on the input side to prevent accidents caused by internal short circuits.

The following table lists the recommended fuses, contactors, and circuit breakers.

Table 4–1 Model selection of fuses, contactors, and circuit breakers

Model of Power Supply Unit	Rated Input Current (Heavy Load) (A)	Recommended Fuse			Recommended contactor	Recommended Circuit Breaker
		Semiconductor Fuse (Bussmann)		Semiconductor Fuse (Class J)		
		Rated Current (A)	Model	Rated Current (A)	Rated Current (A)	Rated Current (A)
Single-phase 200–240 V						
MD800-0-2S24 MD800-0-2S24B	24	40	FWP-40B	35	26	35
MD800-0-2S40 MD800-0-2S40B	40	60	FWP-60B	60	50	60
Three-phase 380–480 V						
MD800-0-4T12 MD800-0-4T12B	12	25	FWP-25B	25	16	25
MD800-0-4T22 MD800-0-4T22B	22	50	FWP-50B	50	26	50
MD800-0-4T41 MD800-0-4T41B	41	60	FWP-60B	60	50	60

4.1.2 AC Input Reactor

The AC input reactor is an option used to suppress the harmonics in the input current. In applications where strong suppression of harmonics is required, install an external AC input reactor.

Model and Dimensions (Inovance)

The models and dimensions of the recommended Inovance AC input reactors are as follows.

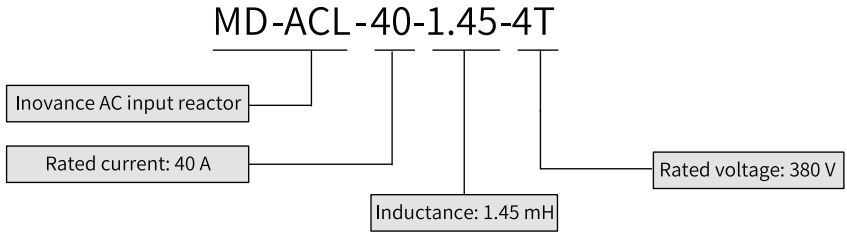

Figure 4-1 AC input reactor model

Table 4-2 Model selection of the AC input reactor (Inovance)

Model of Power Supply Unit	Rated Input Current (Heavy Load) (A)	Reactor Model	Inductance (mH)	Power Consumption (W)
Single-phase 200–240 V				
MD800-0-2S24 MD800-0-2S24B	24	/	/	/
MD800-0-2S40 MD800-0-2S40B	40	/	/	/
Three-phase 380–480 V				
MD800-0-4T12 MD800-0-4T12B	12	MD-ACL-15-1.9-4T-4%	1.9	-
MD800-0-4T22 MD800-0-4T22B	22	MD-ACL-30-0.93-4T-4%	0.93	-
MD800-0-4T41 MD800-0-4T41B	41	MD-ACL-50-0.56-4T-4%	0.56	-

Dimensions of the AC input reactor

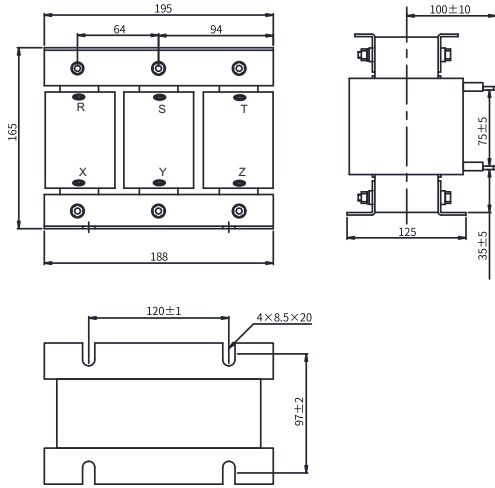

Figure 4-2 Dimensions of 15 A AC input reactor

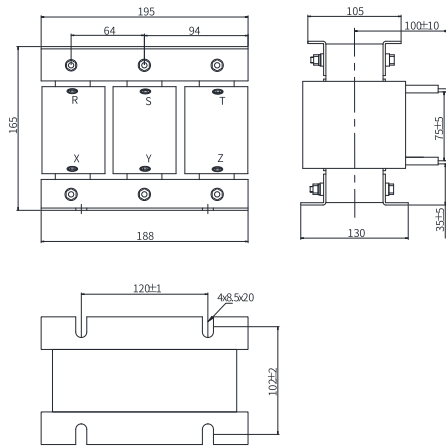

Figure 4-3 Dimensions of 30 A AC input reactor

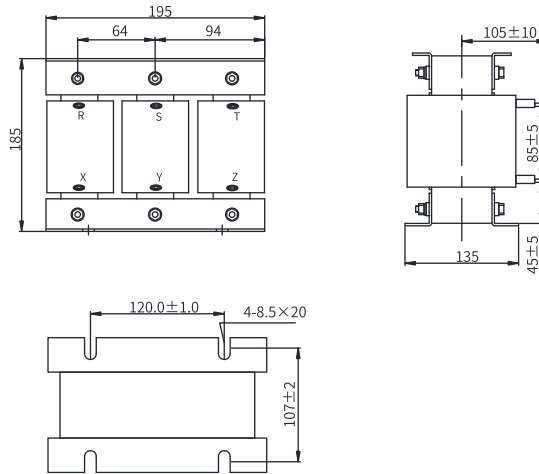

Figure 4-4 Dimensions of 50 A AC input reactor

Model and Dimensions (Schaffner)

The models of the recommended Schaffner AC input reactors are as follows.

Table 4-3 Model selection of the AC input reactor (Schaffner)

Model of Power Supply Unit	Rated Input Current (Heavy Load) (A)	Reactor Model	Inductance (mH)	Power Consumption (W)
Single-phase 200–240 V				
MD800-0-2S24 MD800-0-2S24B	24	/	/	/
MD800-0-2S40 MD800-0-2S40B	40	/	/	/
Three-phase 380–480 V				
MD800-0-4T12 MD800-0-4T12B	12	RWK 3044-18-89-E0XXX	1.67	103
MD800-0-4T22 MD800-0-4T22B	22	RWK 3044-35-92-E0XXX	0.83	151
MD800-0-4T41 MD800-0-4T41B	41	RWK 3044-48-92-E0XXX	0.61	172

4.1.3 Input Filter



4.1.3.1 EMC Filter

To enable the AC drive to meet the EN IEC 61800-3 emission requirements, the AC drive must be connected to the external EMC filter listed in the following table.

Inovance and Schaffner EMC filters can be used.

Appearance

Table 4-4 Standard EMC filter models and appearance

Filter Model		Appearance
Schaffner	FN2010N series	
	FN3288 series	
Inovance	FIL800 series	

Model

Select the filter based on the rated input current of the AC drive according to the following table.

Table 4-5 Schaffner filter model selection

Model of Power Supply Unit	Rated Input Current (Heavy Load) (A)	Filter Model	Power Consumption (W)
Single-phase 200-240 V			
MD800-0-2S24 MD800-0-2S24B	24	FN 2010N-30-08	/

Model of Power Supply Unit	Rated Input Current (Heavy Load) (A)	Filter Model	Power Consumption (W)
MD800-0-2S40 MD800-0-2S40B	40	FN 2010N-60-24	/
Three-phase 380–480 V			
MD800-0-4T12 MD800-0-4T12B	12	FN3288-16-44-C...R65	/
MD800-0-4T22 MD800-0-4T22B	22	FN3288-20-33-C...R65	/
MD800-0-4T41 MD800-0-4T41B	41	FN3288-40-33-C...R65	/

Table 4–6 Inovance filter model selection

Model of Power Supply Unit	Rated Input Current (Heavy Load) (A)	Filter Model	Power Consumption (W)
Single-phase 200–240 V			
MD800-0-2S24 MD800-0-2S24B	24	FIL800-2S-040	/
MD800-0-2S40 MD800-0-2S40B	40	FIL800-2S-040	/
Three-phase 380–480 V			
MD800-0-4T12 MD800-0-4T12B	12	FIL800-4T-042	/
MD800-0-4T22 MD800-0-4T22B	22	FIL800-4T-042	/
MD800-0-4T41 MD800-0-4T41B	41	FIL800-4T-042	/

Dimensions

The filter dimensions are as follows.

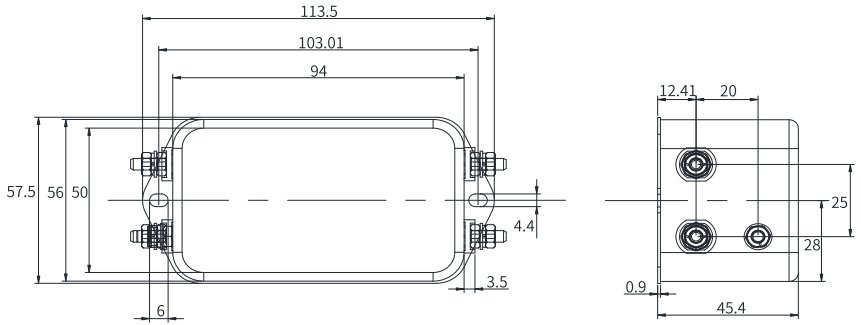

Figure 4-5 Filter dimensions (FN2010N-30-08) (unit: mm)

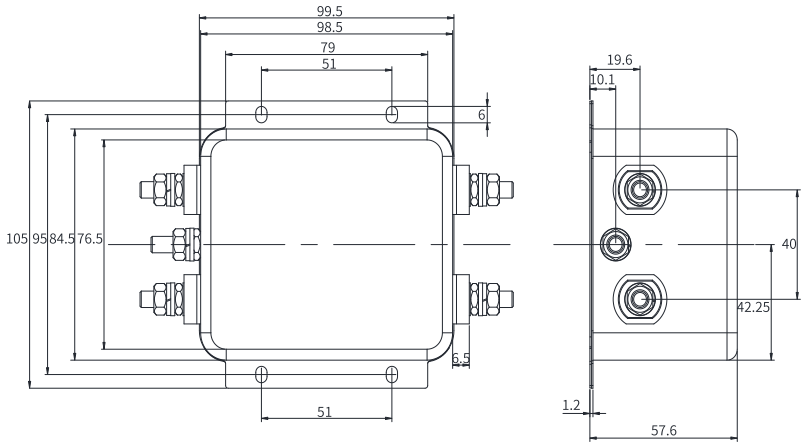

Figure 4-6 Filter dimensions (FN2010N-60-24) (unit: mm)

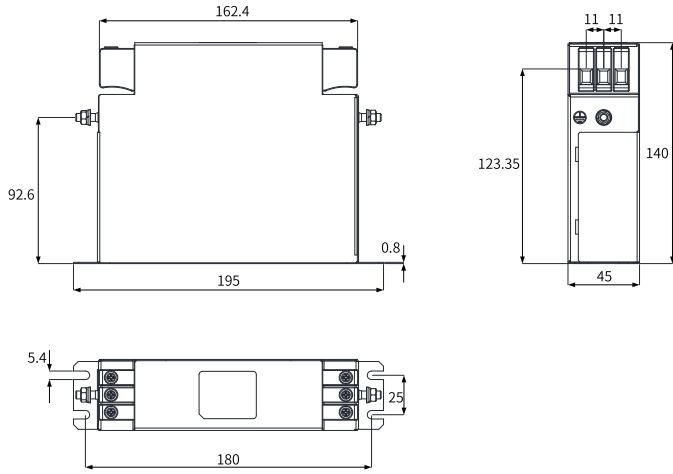

Figure 4-7 Filter dimensions (FN3288-16-44) (unit: mm)

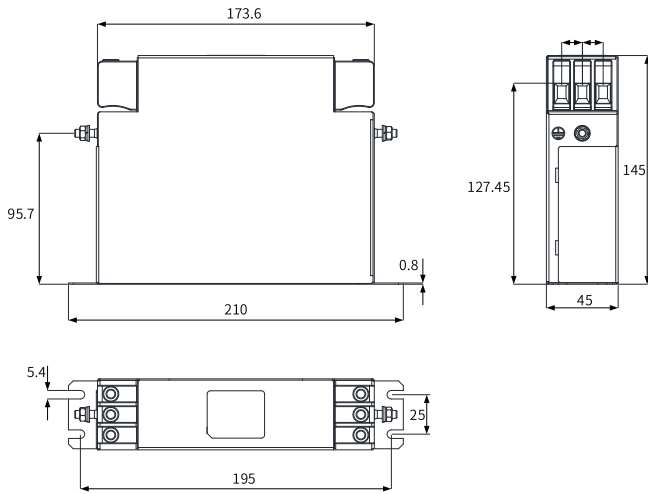

Figure 4-8 Filter dimensions (FN3288-20-25-33) (unit: mm)

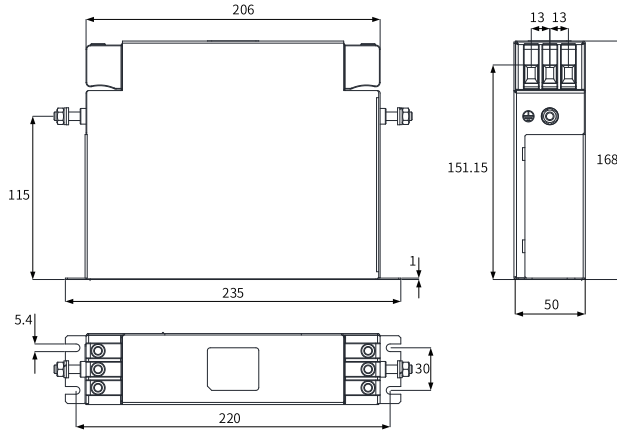

Figure 4-9 Filter dimensions (FN3288-40-33) (unit: mm)

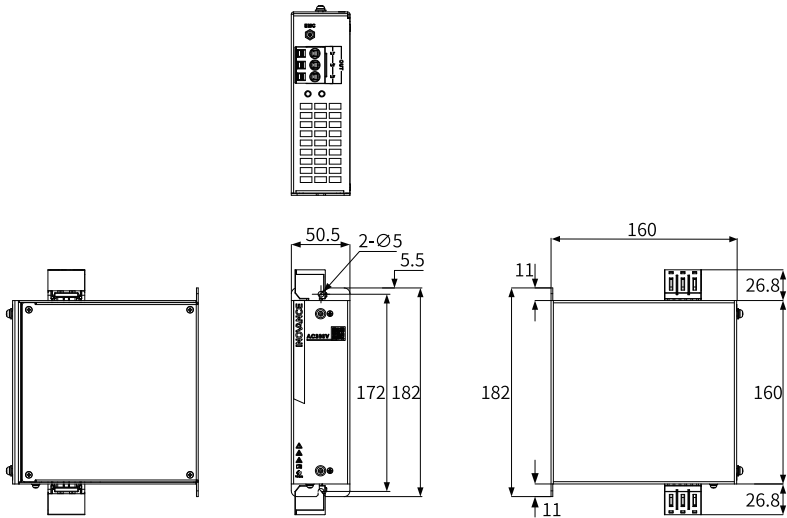

Figure 4-10 Inovance Filter dimensions (FIL800) (unit: mm)

4.1.3.2 Simple Filter

A simple filter can be used to suppress the RF electromagnetic noise generated from the power grid and the AC drive during operation. For equipment using residual current devices (RCDs), a simple filter can be installed at the input end of the drive to avoid RCD malfunctions during operation, as shown in ["Figure 4-12" on page 104](#) *Installation of the simple filter.*

The simple filter must be grounded securely and the cable between the filter and AC drive must be shorter than 30 cm. The grounding terminal of the simple filter must be connected to the grounding terminal of the drive. The grounding cable must be as short as possible and cannot exceed 30 cm.

Dimensions

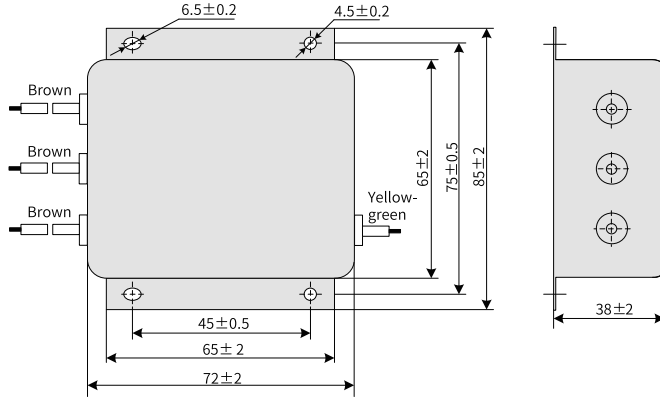

Figure 4-11 Outline dimensions of the simple filter

Table 4-7 Outline dimensions of the simple filter

Model	Code	Dimensions (Length × Width × Height) (unit: mm)	Mounting Dimensions (Length × Width) (unit: mm)
Cxy-1-1	11025018	85 × 72 × 38	45 × 75

Installation Method

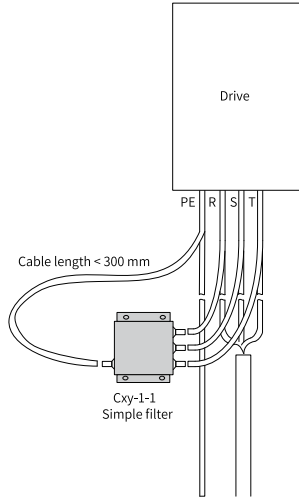

Figure 4-12 Installation of the simple filter

4.1.4 Braking Components

Resistance Selection of the Braking Resistor

During braking, almost all regenerative energy of the motor is consumed by the braking resistor. The resistance of the braking resistor is calculated by the following formula: $U \times U/R = P_b$.

U indicates the braking voltage at system stable braking. (U varies with systems. For three-phase 380–480 V, the default braking voltage of AC drive is 760 V. For single-phase 200–240 V, the default braking voltage of AC drive is 360V. It can be adjusted by parameter F1-02 of the power supply unit.)

P_b indicates the braking power.

Power Selection of the Braking Resistor

In theory, the power of braking resistor is the same as the braking power. However, in consideration of derating K, the power of braking resistor is calculated using the following formula: $K \times P_r = P_b \times D$.

K is set to 50% or an approximate value.

P_r indicates the power of the braking resistor.

D indicates the braking frequency (percentage of regenerative process to whole deceleration).

The following two formulas can be obtained:

$$K \times P_r = P_b \times D = U \times U/R \times D$$

$$Pr = (U \times U \times D) / (R \times K)$$

The braking resistor power is calculated accordingly.

K is the derating coefficient of the braking resistor. A small value of K prevents the braking resistor from overheating. K can be increased properly if the heat dissipation condition is good, but cannot exceed 50%. Otherwise, the braking resistor may be overheated, which may cause a fire.

Braking frequency (D) is determined by applications. Typical values of braking frequency in different applications are listed in "Table 4-8 " on page 105.

Table 4-8 Typical values of braking frequency in different applications

Application	General applications (such as translational conveying)	Vertical lifting	Machine tool spindle	Winding and unwinding
Braking Frequency	10%	20% to 30%	30% to 50%	20% to 30%

Braking Unit Models

Table 4-9 Model selection of braking component

Model of Power Supply Unit	Total Power of Drive Unit (kW)	Braking Unit	125% Braking Torque (10% ED; Max. 10s)		Minimum Braking Resistance (Ω)	Maximum Braking Current (A)	Braking Power (kW)
		Model	Recommended Braking Resistor Specifications	Number of Braking Resistors			
Single-phase 200-240 V							
MD800-0-2S24 MD800-0-2S24B	2.2	Built-in optional	450 W 66 Ω	1	40	10	2.8
MD800-0-2S40 MD800-0-2S40B	3.7		740 W 40 Ω	1	20	20	4.7
Three-phase 380-480 V							
MD800-0-4T12 MD800-0-4T12B	3.7	Built-in optional	740 W 150 Ω	1	55	15	4.7
MD800-0-4T22 MD800-0-4T22B	7.5		1500 W 75 Ω	1	32	25	9.4
MD800-0-4T41 MD800-0-4T41B	15		3000 W 38 Ω	1	20	40	18.8

Note

- The minimum braking resistance in the preceding table supports the operating condition with ED of 10% and the longest time for single braking of 10s.
- The initial braking voltage can be adjusted with the grid voltage. If the default initial braking voltage is increased, the resistance of the braking resistor must be increased. The default initial braking voltage is 760 V for three-phase 380 V to 480 V models and 360 V for single-phase 200 V to 240 V models.
- The data in the preceding table is for reference only. You can select the resistance and power of the braking resistor as required. (Note that the resistance cannot be lower than the recommended minimum value, but the power can exceed the recommended value.) The braking resistor model depends on the generation power of the motor in the actual system and is also related to the system inertia, deceleration time, and potential energy load. Select a proper braking resistor as required. A larger system inertia requires shorter deceleration time and more frequent braking. In this case, you need to select a braking resistor with higher power and lower resistance.

4.1.5 Output Reactor

With an output reactor installed on the output side of the AC drive, the excessive dV/dt can be reduced, lowering the voltage stress on the motor winding. This protects the motor winding, lowers the motor temperature, and prolongs the service life of the motor.

Model and Dimensions (Inovance)

The models and dimensions of the recommended Inovance AC output reactors are as follows.

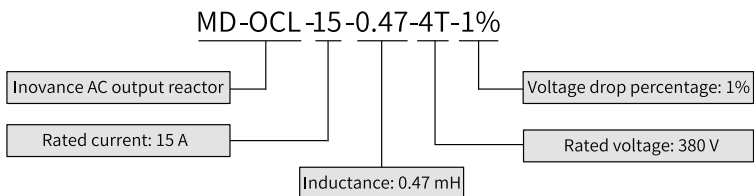

Figure 4-13 AC output reactor model

Table 4–10 Model selection of the AC output reactor (Inovance)

Drive Unit Model	Rated Output Current (Heavy Load) (A)	Motor Capacity (kW)	Reactor Model	Inductance (mH)	Power Consumption (W)
Single-phase 200–240 V					
MD800-1-2T1R7 MD800-1-2T1R7S MD800-2-2T1R7 MD800-2-2T1R7S	1.7	0.2	MD-OCL-5-1.4-4T-1%	1.4	15
MD800-1-2T3 MD800-1-2T3S MD800-2-2T3 MD800-2-2T3S	3.0	0.4	MD-OCL-5-1.4-4T-1%	1.4	15
MD800-1-2T5 MD800-1-2T5S MD800-2-2T5 MD800-2-2T5S	5.0	0.75	MD-OCL-5-1.4-4T-1%	1.4	15
MD800-1-2T8 MD800-1-2T8S MD800-2-2T8 MD800-2-2T8S	8.0	1.5	MD-OCL-5-1.4-4T-1%	1.4	15
MD800-1-2T11 MD800-1-2T11S MD800-2-2T11 MD800-2-2T11S	11.0	2.2	MD-OCL-7-1.0-4T-1%	1.0	20
Three-phase 380–480 V					
MD800-1-4T1R8 MD800-1-4T1R8S MD800-2-4T1R8 MD800-2-4T1R8S	1.8	0.4	MD-OCL-5-1.4-4T-1%	1.4	15
MD800-1-4T3R4 MD800-1-4T3R4S MD800-2-4T3R4 MD800-2-4T3R4S	3.4	0.75	MD-OCL-5-1.4-4T-1%	1.4	15
MD800-1-4T4R8 MD800-1-4T4R8S MD800-2-4T4R8 MD800-2-4T4R8S	4.8	1.5	MD-OCL-5-1.4-4T-1%	1.4	15
MD800-1-4T5R5 MD800-1-4T5R5S MD800-2-4T5R5 MD800-2-4T5R5S	5.5	2.2	MD-OCL-7-1.0-4T-1%	1.0	20
MD800-1-4T9R5 MD800-1-4T9R5S MD800-2-4T9R5 MD800-2-4T9R5S	9.5	3.7	MD-OCL-10-0.7-4T-1%	0.7	25

Drive Unit Model	Rated Output Current (Heavy Load) (A)	Motor Capacity (kW)	Reactor Model	Inductance (mH)	Power Consumption (W)
MD800-1-4T13 MD800-1-4T13S	13.0	5.5	MD-OCL-15-0.47-4T-1%	0.47	28
MD800-1-4T17 MD800-1-4T17S	17.0	7.5	MD-OCL-20-0.35-4T-1%	0.35	32

Dimensions of the AC output reactor

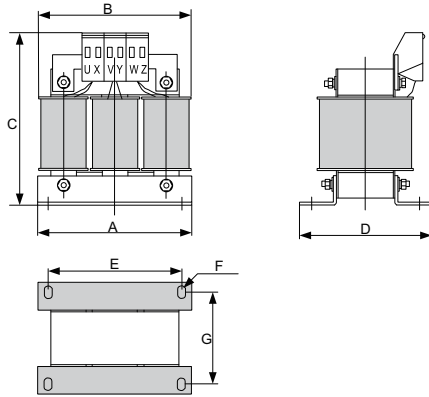

Figure 4-14 Dimensions of 5-10 A AC output reactor

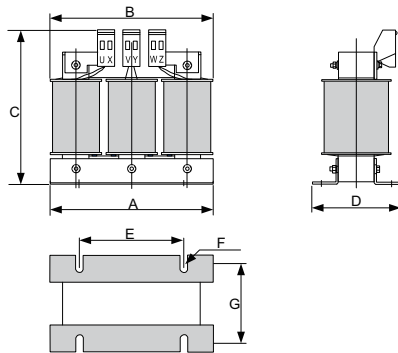

Figure 4-15 Dimensions of 15 A AC output reactor

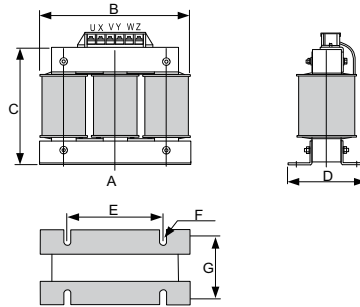

Figure 4-16 Dimensions of 20 A AC output reactor

Table 4-11 Dimensions of 5-20 A AC output reactors (unit: mm)

Rated Current (A)	A	B	C	D	E	F	G
5	105±1	110	130	84±2	91±1	4-6×11	65±2
7	105±1	110	130	84±2	91±1	4-6×11	65±2
10	105±1	110	130	84±2	91±1	4-6×11	65±2
15	148±1	155	140	76±2	95±1	4-6×15	61±2
20	148±1	155	165	76±2	95±1	4-6×15	61±2

Model and Dimensions (Schaffner)

The models and dimensions of the recommended Schaffner AC output reactors are as follows.

Table 4-12 Model selection of the AC output reactor (Schaffner)

Drive Unit Model	Rated Output Current (Heavy Load) (A)	Motor Capacity (kW)	Applicable Reactor	Inductance (mH)	Power Consumption (W)
Single-phase 200-240 V					
MD800-1-2T1R7 MD800-1-2T1R7S MD800-2-2T1R7 MD800-2-2T1R7S	1.7	0.2	RWK 305-4-KL	1.47	22
MD800-1-2T3 MD800-1-2T3S MD800-2-2T3 MD800-2-2T3S	3.0	0.4	RWK 305-4-KL	1.47	22
MD800-1-2T5 MD800-1-2T5S MD800-2-2T5 MD800-2-2T5S	5.0	0.75	RWK 305-7.8-KL	0.754	25

Drive Unit Model	Rated Output Current (Heavy Load) (A)	Motor Capacity (kW)	Applicable Reactor	Inductance (mH)	Power Consumption (W)
MD800-1-2T8 MD800-1-2T8S MD800-2-2T8 MD800-2-2T8S	8.0	1.5	RWK 305-10-KL	0.588	30
MD800-1-2T11 MD800-1-2T11S MD800-2-2T11 MD800-2-2T11S	11.0	2.2	RWK 305-14-KL	0.42	34
Three-phase 380–480 V					
MD800-1-4T1R8 MD800-1-4T1R8S MD800-2-4T1R8 MD800-2-4T1R8S	1.8	0.4	RWK 305-4-KL	1.47	22
MD800-1-4T3R4 MD800-1-4T3R4S MD800-2-4T3R4 MD800-2-4T3R4S	3.4	0.75	RWK 305-4-KL	1.47	22
MD800-1-4T4R8 MD800-1-4T4R8S MD800-2-4T4R8 MD800-2-4T4R8S	4.8	1.5	RWK 305-7.8-KL	0.754	25
MD800-1-4T5R5 MD800-1-4T5R5S MD800-2-4T5R5 MD800-2-4T5R5S	5.5	2.2	RWK 305-7.8-KL	0.754	25
MD800-1-4T9R5 MD800-1-4T9R5S MD800-2-4T9R5 MD800-2-4T9R5S	9.5	3.7	RWK 305-14-KL	0.42	34
MD800-1-4T13 MD800-1-4T13S	13.0	5.5	RWK 305-17-KL	0.346	38
MD800-1-4T17 MD800-1-4T17S	17.0	7.5	RWK 305-32-KL	0.184	55

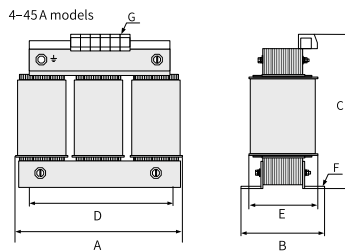

Figure 4-17 Dimensions of 4-32 A output reactor

Table 4–13 Mounting dimensions of 4–17 A AC output reactors (unit: mm)

Series	A	B	C	D	E	F	G
4 and 7.8 A	100	Max. 60	Max. 115	56	34	4.8×9	2.5 mm ²
10 A	100	Max. 70	Max. 115	56	43	4.8×9	2.5 mm ²
14 A	125	Max. 70	Max. 135	100	45	5×8	2.5 mm ²
17 A	125	Max. 75	Max. 135	100	55	5×8	2.5 mm ²
32 A	155	Max. 95	Max. 170	130	56	85×12	2.5 mm ²

4.1.6 Magnetic Ring and Buckle

Model

The magnetic ring is mainly used on the input side or output side of the AC drive. Install it as close to the drive as possible. When it is installed on the input side, the noise in the input power supply system of the drive can be suppressed. When it is installed on the output side, the interference generated by the drive to external devices can be suppressed and the bearing current can be lowered.

The magnetic ring or buckle can also be used to suppress the leakage current or other signal cable interference in some applications.

- Amorphous magnetic ring: high permeability when within 1 MHz, good suppression of drive interference, but high cost
- Ferrite magnetic buckle: good performance when in the frequency band above 1 MHz, suppression of interference noise of various signal cables, low cost, and convenient and neat for installation

Table 4–14 Appearance and models of the magnetic rings and buckle

Category	Model	Appearance
Magnetic ring	DY644020H	
	DY805020H	
	DY1207030H	
Magnetic buckle	DYR-130-B	

Dimensions

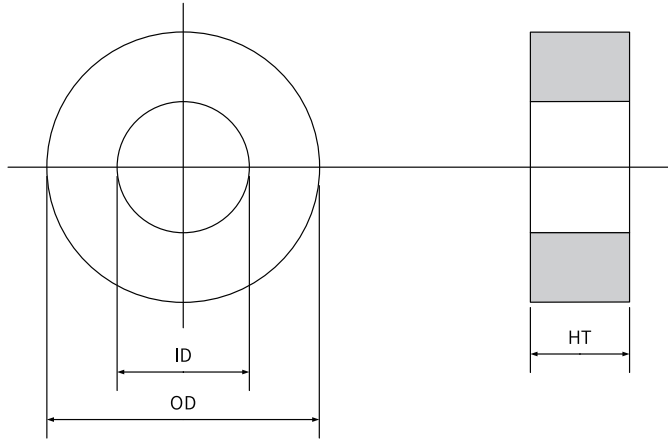

Figure 4-18 Magnetic ring dimensions

Table 4-15 Magnetic ring dimensions

Magnetic Ring Model	Dimensions (OD × ID × HT) (mm)
DY644020H	64 × 40 × 20
DY805020H	80 × 50 × 20
DY1207030H	120 × 70 × 30

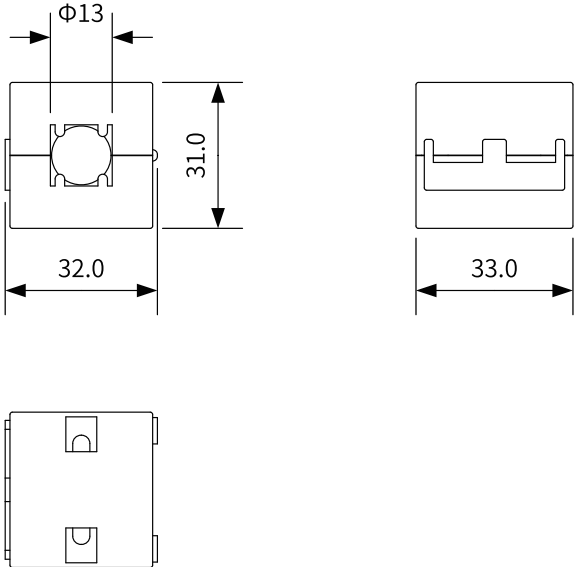

Figure 4-19 Magnetic buckle dimensions

Table 4-16 Magnetic buckle dimensions

Magnetic Buckle Model	Overall Dimensions (Length x Outer Diameter x Inner Diameter) (mm)
74271225	32.8 × 28 × 13

4.1.7 Motor

To effectively protect motors with different loads, the overload protection gain of motors must be set according to their overload capacity. Generally, the default value of protection gain is used. However, it can be changed according to the actual motor heating conditions when any of the following conditions occurs:

- The motor works in an environment of high temperature.
- The motor keeps cyclic running with short single cycle and frequent acceleration/ deceleration.

The motor overload protection curve is an inverse time lag curve, as shown in the following figure.

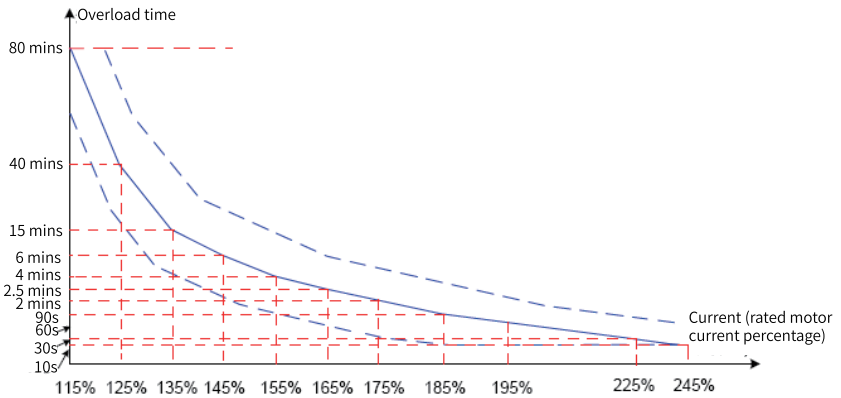

Figure 4-20 Motor overload protection curve

When the motor running current reaches 175% of the rated motor current and the motor runs at this level for 2 minutes, E11.00 (motor overload) is detected. When the motor running current reaches 115% of the rated motor current and the motor runs at this level for 80 minutes, E11.00 (motor overload) is detected.

Example 1: The rated motor current is 100 A.

If F9-01 (Motor overload protection gain) is set to 1.00, when the motor running current reaches 125 A (125% of 100 A) and the motor runs at 125 A for 40 minutes, the AC drive reports E11.00 (motor overload). If F9-01 (Motor overload protection gain) is set to 1.20, when the motor running current reaches 125 A (125% of 100 A) and the motor runs at 125 A for 48 minutes (40 x 1.2), the AC drive reports E11.00 (motor overload).

Note

The maximum overload time is 80 minutes and the minimum overload time is 10 seconds.

Example 2: If the AC drive is required to report the overload fault when the motor runs at 150% of the rated current for 2 minutes.

According to the motor overload curve, 150% (I) is in the range of 145% (I1) and 155% (I2). 145% corresponds to overload protection time 6 minutes (T1) and 155% corresponds to overload protection time 4 minutes (T2). It can be concluded that in default settings, the overload protection time for 150% rated current of the motor is 5 minutes. It can be calculated as follows:

$$T = T1 + (T2 - T1) \times (I - I1) / (I2 - I1) = 6 + (4 - 6) \times (150\% - 145\%) / (155\% - 145\%) = 5 \text{ minutes}$$

Then, calculate the motor overload protection gain from the following formula: $F9-01 = \text{Desired overload protection time} / \text{Corresponding overload protection time} = 2 / 5 = 0.4$.



Note: Set F9-01 (Motor overload protection gain) properly based on the actual overload capacity. If the value of F9-01 (Motor overload protection gain) is set too high, the motor may be damaged because the motor overheats but the AC drive does not report the alarm timely.

When the motor overload detection level reaches the value of F9-02 (Motor overload pre-warning coefficient), the DO or fault relay outputs the motor overload pre-warning signal. The value of F9-02 (Motor overload pre-warning coefficient) is the percentage of the time duration during which the motor runs continuously without reporting the overload fault.

On the condition that F9-01 (Motor overload protection gain) is set to 1.00 and F9-02 (Motor overload pre-warning coefficient) is set to 80%, when the motor running current reaches 145% of the rated motor current and the motor runs at this level for 4.8 minutes ($80\% \times 6$), the DO terminal or fault relay outputs the motor overload pre-warning signal.

The motor overload pre-warning function enables the AC drive to send a warning signal to the control system through the DO before motor overload protection. It is used to determine how early to send the pre-warning signal before the motor overload protection. The higher the value is, the later the pre-warning signal is sent. When the accumulative output current of the AC drive is higher than the value of the overload time (value Y of motor overload protection inverse time-lag curve) multiplied by F9-02 (Motor overload pre-warning coefficient), the multi-functional DO terminal of the AC drive outputs a motor overload pre-warning signal.

When F9-02 is set to 100%, the motor overload pre-warning and the motor overload protection are performed simultaneously.

4.2 External LCD Operating Panel

SOP-20 is an external operating panel provided by Inovance for the AC drive. It adopts the LED display and has the same operation mode as the operating panel on the AC drive. It is optional and easy for commissioning. Its appearance and mounting dimensions are shown below.

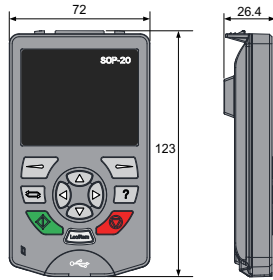

Figure 4-21 Overall dimensions of the external LCD operating panel (unit: mm)

5 Installation Requirements for Options

5.1 AC Input Reactor

The AC input reactor is an option used to suppress the harmonics in the input current. In applications where strong suppression of harmonics is required, install an external AC input reactor.

If an AC input reactor is required, ensure that sufficient installation space is reserved in the cabinet.

5.2 Output Reactor

With an output reactor installed on the output side of the AC drive, the excessive dV/dt can be reduced, lowering the voltage stress on the motor winding. This protects the motor winding, lowers the motor temperature, and prolongs the service life of the motor.

5.3 Fuse, Contactor, and Circuit Breaker



When the fuse is damaged or the circuit breaker trips, do not immediately energize the product or operate the peripheral equipment. Wait at least for the time specified on the warning label to prevent personal injury and equipment damage.

To meet the requirements of IEC/EN 61800-5-1 and UL61800-5-1, a fuse/circuit breaker must be connected on the input side to prevent accidents caused by internal short circuits.

5.4 EMC Filter

The optional EMC filter is able to meet the EN61800-3 category C2 emission limits. EMC filters are recommended to be installed according to the following requirements:

- The filter must be reliably grounded.
- The EMC filter must be installed close to the input terminals of the equipment, and the cables connecting them must be shorter than 30 cm.
- The grounding terminal of EMC filter and the grounding terminal of equipment must be connected together, and the filter and the equipment must be installed on the same conductive installation surface, which is connected to the main ground of the cabinet.

- The LINE terminal of the EMC filter must be connected to the power grid, and the LOAD terminal must be connected to the AC drive.

5.5 Simple Filter

When no standard EMC filter is installed, a simple filter (capacitor box) can also be used to suppress the RF electromagnetic noise generated from the power grid and the AC drive during operation. The simple filter must be grounded securely and the cable between the filter and AC drive must be shorter than 30 cm.

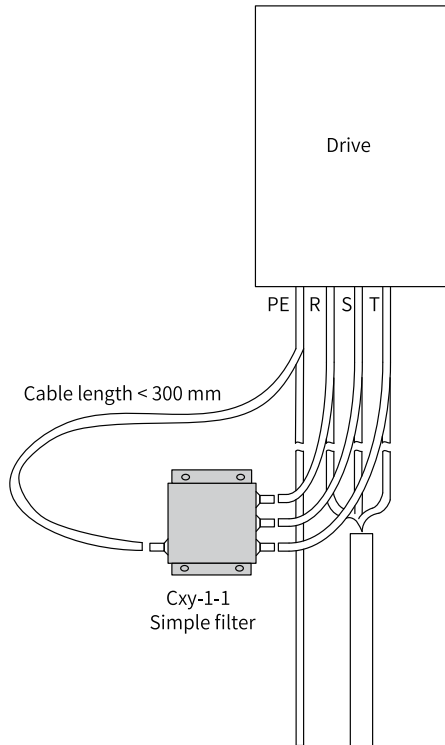

Figure 5-1 Installation of the simple filter

5.6 Magnetic Ring and Buckle

The magnetic ring can be used on the input side or output side of the AC drive. Install it as close to the AC drive as possible. When it is installed on the input side, the noise in the input power supply system of the AC drive can be suppressed. When it is installed on the output side, the interference generated by the AC drive to external devices can be suppressed and the bearing current can be lowered.

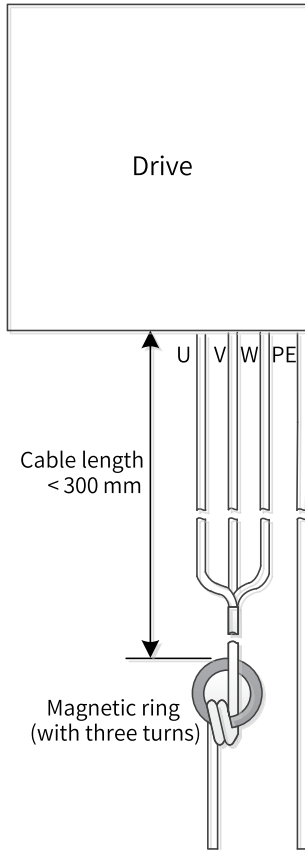

Figure 5-2 Installation of the magnetic ring

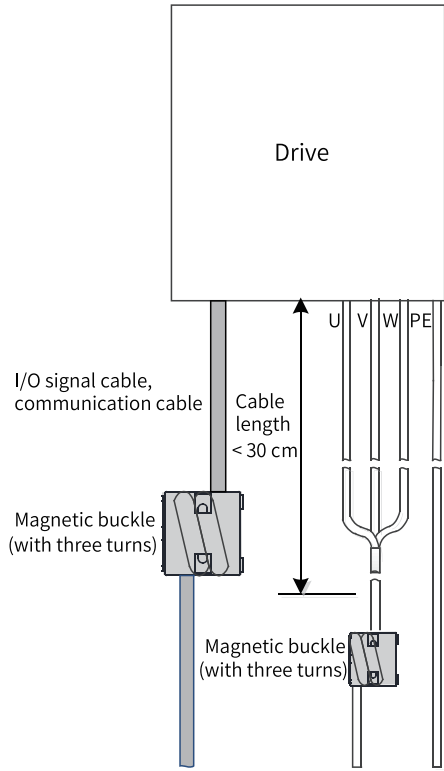

Figure 5-3 Installation of the magnetic buckle

Note

The R/S/T or U/V/W cables must pass through the same magnetic ring to suppress the common mode noise.

6 Solutions to Common EMC Interference Problems

6.1 RCD Malfunction

Select a residual current device (RCD) according to the following requirements:

- The AC drive will generate a certain high-frequency leakage current during operation. To avoid malfunction of the RCD, select an RCD with an operating current of not lower than 100 mA for each AC drive.
- When multiple AC drives connected in parallel share one RCD, the operating current of the RCD must be not lower than 300 mA.
- Recommended RCD manufacturers are Chint Electric and Schneider.

When an RCD malfunctions, perform troubleshooting according to the following table.

Table 6-1 Troubleshooting for leakage current

RCD Tripped	Possible Cause	Solution
RCD tripped upon power-on immediately	The anti-interference performance of the RCD is poor.	<ol style="list-style-type: none"> 1. Use an RCD of recommended manufacturers. 2. Use an RCD with higher operating current. 3. Move the unbalanced load to the front end of the RCD. 4. If an EMC filter unit is installed, disconnect the EMC screws. 5. If an EMC filter is installed, disconnect the EMC filter.
	The operating current of the RCD is too low.	
	The back end of RCD is connected with an unbalanced load.	
	The to-ground capacitance at the front end of the AC drive is high.	
RCD tripped during operation	The anti-interference performance of the RCD is poor.	<ol style="list-style-type: none"> 1. Use an RCD of recommended manufacturers. 2. Install an EMC filter unit or EMC filter. 3. Install a simple filter on the input side of this product, and wind magnetic rings on LN and RST cables near the RCD. 4. Use an RCD with higher rated operating current. 5. Reduce the carrier frequency properly without affecting the performance. 6. Use shorter motor cables.
	The operating current of the RCD is too low.	
	The back end of RCD is connected with an unbalanced load.	
	The to-ground distributed capacitance of the motor cables and motors is too high.	

6.2 Harmonic Suppression

To suppress the higher harmonic current of this product and improve the power factor, install an AC input reactor on the input side of the product. This will enable the product to meet standard requirements.

6.3 Control Circuit Interference

6.3.1 High-speed Pulse Interference

Make rectification according to the following table.

Step	Solution
1	Use the shielded twisted-pair (STP) and ground the STP at both ends.
2	Connect the motor enclosure to the PE of the AC drive.
3	Connect the PE of the AC drive to the PE of the grid.
4	Add an equipotential bonding wire between the host controller and the AC drive.
5	Separate the signal cable and power cable at a distance of at least 30 cm.
6	Add a magnetic buckle to the signal cable, or wind the signal cable on the magnetic ring for one to two turns.
7	Wind the output U/V/W cables of the AC drive on a magnetic ring for two to four turns.
8	Use a shielded power cable and ground the shielding layer securely.

6.3.2 Common I/O Signal Interference

This product generates very strong interference. Although EMC measures are taken, the interference may still exist due to improper cabling or grounding during use. When the product interferes with other devices, the following solutions can be adopted.

Step	Solution
1	Use the shielded cables as the I/O signal cables, with the shielding layer connected to the PE terminal.
2	Reliably connect the PE terminal of the motor to the PE terminal of the AC drive, and connect the PE terminal of the AC drive to the PE of the power grid.
3	Add an equipotential bonding wire between the host controller and the AC drive.
4	Wind the output U/V/W cables of the AC drive on a magnetic ring for two to four turns.

Step	Solution
5	Increase the capacitor filter at the low-speed DI. The recommended maximum value is 0.1 μF . The required capacitor voltage withstanding level is 50 V and above.
6	Increase the capacitor filter at the AI. The recommended maximum value is 0.22 μF . The required capacitor voltage withstanding level is 50 V and above.
7	Add a magnetic buckle to the signal cable, or wind the signal cable on the magnetic ring for one to two turns.
8	Use a shielded power cable and ground the shielding layer securely.
9	Try to remove the grounding screw on the control board. For details, see "3.4.2 Grounding of the Control Board" on page 89 Grounding of the Control Board .

6.4 Communication Interference

6.4.1 RS485 and CAN Communication Interference

Make rectification according to the following table.

Step	Solution
1	Add a 120 Ω termination resistor at both ends of the bus.
2	Use the multi-core shielded twisted-pair (STP) instead, and ground the shielding layer at both ends.
3	Separate the communication cable and power cable at a distance of at least 30 cm.
4	For multi-node communication, adopt the daisy chain mode.
5	For multi-node communication, add an equipotential bonding wire between the nodes.
6	Add a magnetic buckle at both ends of the communication cable, or wind the communication cable on the magnetic ring for one to two turns.
7	Wind the output U/V/W cables of the AC drive on a magnetic ring for two to four turns.
8	Use a shielded power cable and ground the shielding layer securely.

6.4.2 EtherCAT and PROFINET Communication Interference

Make rectification according to the following table.

No.	Step
1	Check whether the communication network cables meet the specification requirements of shielded Cat 5e cables.
2	Check whether the communication port is loose or in poor contact.
3	Separate the communication cable and power cable at a distance of at least 30 cm.
4	For multi-node communication, add an equipotential bonding wire between the nodes.
5	The maximum cable length allowed between two nodes is 100 m.
6	Add a magnetic buckle at both ends of the communication cable and wind the communication cable for one to two turns.
7	Wind the output U/V/W cables of the AC drive on a magnetic ring for two to four turns.
8	Use a shielded power cable and ground the shielding layer securely.
9	Installation the EtherCAT communication expansion card to optional expansion card slot 2.

7 Standards Compliance

7.1 Compliance with Certifications, Directives and Standards

The following table lists the certifications standards that the product may comply with. For details about the acquired certificates, see the certification marks on the product nameplate.

Certification Name	Directive Name		Standards Compliance
CE certification	EMC directive	2014/30/EU	EN IEC 61800-3
	LVD	2014/35/EU	EN 61800-5-1
	RoHS directive	2011/65/EU	EN 50581
UL certification	-		UL61800-5-1 C22.2 No.274-17
Functional safety certification (STO)	Machinery directive	2006/42/EC	EN 61800-5-2 EN 62061 :2005/A2 EN ISO 13849-1 EN 61508 ed.2

Note

The product meets the requirements of the latest version of instructions and standards of the CE/UL certification.

7.2 CE Certification

7.2.1 Precautions for Compliance with European Standards



Figure 7-1 CE mark

- The "CE Mark" indicates compliance with the directives for safety (LVD), electromagnetic compatibility (EMC), and environmental protection (RoHS).
- It is required when engaging in business and commerce (manufacturing, importing, and selling) in Europe.

- This product conforms to the Low Voltage Directive (LVD), Electromagnetic Compatibility (EMC), and Restriction of Hazardous Substances (RoHS) Command, and is therefore marked with CE.
- The machinery and devices equipped with this product must also meet CE requirements when sold in Europe.
- The integrator who integrates this product with other devices has the responsibility of ensuring compliance with CE standards when the CE mark is labeled on the final device.

7.2.2 Conditions for Compliance with the EMC Directive

- This product satisfies the European EMC directive 2014/30/EU and the EN 61800-3. It is applied to both the first environment and the second environment.



When applied in the first environment, this product may generate radio interference. Besides the CE compliance described in this chapter, take measures to avoid the radio interference if required.

- To satisfy the EMC directive and standard, install the EMC filter on the input side of the product, connect a recommended shielded cable on the output side, ground the filter reliably, and connect the shielding layer of output cable in 360°.



The integrator of the system installed with this product is responsible for compliance of the system with the European EMC directive and EN IEC 61800-3 according to the system application environment.

EMC Specifications

Follow the product requirements during installation. This product meets the requirements of EN IEC 61800-3 standard. See the following table for the maximum allowable motor cable length for conducted and radiated interference.

Table 7-1 Maximum motor cable length allowed for conducted and radiated interference

Product Model	Maximum Cable Length for Conducted Emission		Maximum Cable Length for Radiated Emission	
	Category C1		Category C1	
	Built-in filter	External EMC filter	Built-in filter	External EMC filter
Single-phase products	-	50 m	-	50 m

Table 7-2 Maximum motor cable length allowed for conducted and radiated interference

Product Model	Maximum Cable Length for Conducted Emission		Maximum Cable Length for Radiated Emission	
	Category C2		Category C2	
	Built-in filter	External EMC filter	Built-in filter	External EMC filter
Three-phase products	-	50 m	-	50 m

Introduction to EMC Standard

Electromagnetic compatibility (EMC) describes the ability of electronic and electrical devices or systems to work properly in the electromagnetic environment and not to generate electromagnetic interference that influences other local devices or systems. Therefore, EMC includes the following requirements:

- The electromagnetic interference generated by the equipment in the normal operation process cannot exceed a certain limit.
- The appliance has certain electromagnetic interference in the environment. The degree of immunity, ie electromagnetic sensitivity.

EN IEC 61800-3 defines the following two environments:

- First Environment: This includes domestic premises, and establishments that share a low-voltage power supply network with buildings used for domestic purposes.
- Second Environment: This includes all establishments other than those directly connected to a low-voltage power supply network which supplies buildings used for domestic purposes.

According to the expected use environment, the products are divided into the following four categories:

- Equipment Category C1: power drive system (PDS) of rated voltage less than 1000 V, intended for use in the first environment
- Equipment Category C2: PDS of rated voltage less than 1000 V, which is neither a plug in device nor a movable device and, when used in the first environment, is intended to be installed and commissioned only by a professional person
- Equipment Category C3: PDS of rated voltage less than 1000 V, intended for use in the second environment and not intended for use in the first environment

- Equipment Category C4: PDS of rated voltage equal to or above 1000 V, or rated current equal to or above 400 A, or intended for use in complex systems in the second environment

7.2.3 Conditions for Compliance with the LVD

This product has been tested according to EN61800-5-1, and it complies with the Low Voltage Directive (LVD) completely. To enable machines and devices integrating this drive to comply with the LVD, the following requirements must be met.

Installation Location

Place this product in a location meeting OVC III and PD 2 or below, as specified in IEC 60664-1.

Installation Environment

For installation environment requirements, see "Installation Environment" in *Quick Start Guide (Installation & Commissioning)*.

Requirements on Installation and Protection

- This product must be installed in a fireproof cabinet with doors that provide effective electrical and mechanical protection. The installation must conform to local and regional laws and regulations, and to relevant IEC requirements.
- When installing the product in a cabinet (IP20), install it in structures that cannot be accessed by foreign objects from the top and front.

Main Circuit Wiring Requirements

For details, see ["3.1.2 Main Circuit Wiring Requirements" on page 46](#) *Main Circuit Wiring Requirements*.

Requirements on Protective Devices

To meet the requirements of EN 61800-5-1, a fuse/circuit breaker must be connected on the input side to prevent accidents caused by internal short circuits. For details about the selection of the fuse/circuit breaker, see ["4.1.1 Fuse, Circuit Breaker, and Contactor" on page 94](#) *Fuse, Circuit Breaker, and Contactor*.

7.3 UL or cUL Certification



Figure 7-2 UL/cUL Mark

- The UL/cUL mark is usually attached on products sold in USA and Canada. Products with UL/cUL mark have been inspected and assessed by the UL organization. To pass UL/cUL certification, main built-in components of electrical products must also be UL certified.
- This product has been tested in accordance with UL 61800-5-1 and CSA C22.2 No. 100-14 and has been confirmed to meet UL/CUL requirements. To enable machines and devices integrating this product to comply with UL/cUL standards, the following requirements must be met:

Installation Location

Install this product in a location meeting OVC III and PD 2 or below, as specified in UL61800–5–1.

Ambient Temperature

According to the protection level, the ambient temperature must be maintained within the following range:

Ambient temperature for open type products: -20°C to +60°C

Requirements on Installation

This product is an open type product, which is installed in a cabinet. Its installation requirements are as follows:

This product must be installed in a fireproof final system that provide effective electrical and mechanical protection. The installation must conform to local and regional laws and regulations, and to relevant NEC requirements.

Main Circuit Wiring Requirements



Field installation is not allowed for output terminals BR, (-), and (+).

- Terminals BR and (+) are used to connect options. Do not connect them to the AC power supply.
- To protect the main circuit, separate it from the possible contact surface and provide covers as required.
- The control circuit is a safety extra-low voltage (SELV) circuit, which must be insulated and isolated from other circuits. Make sure that the control circuit is connected to the SELV circuit.
- Note that no foreign matter enters the wiring part of the terminal block.
- Do not carry out welding treatment when using stranded wires.

- The tightening torque of each terminal may be different. Tighten the screws according to the specified tightening torque using a torque screwdriver, ratchet, or wrench.
- If an electric tool is used to tighten the terminal screws, use a low speed setting to avoid damage to the terminal screws.
- Do not tighten the terminal screws at an angle of more than 5 degrees. Otherwise the terminal screws may be damaged.

Control Circuit Wiring Requirements

Wire the control circuit in accordance with UL61800-5-1.

Cable Selection Requirements for the Main Circuit

For the selection of wire dimensions, follow the requirements of National Electrical Code (NEC) and Part 1 of Canadian Electrical Code (CEC) and relevant local regulations.

- Copper wires must be used.
- The recommended cable size of the main circuit is 600V Class 2 heat-resistant indoor PVC cable with a continuous maximum allowable temperature of 75 °C. The following conditions are used as premises:
 1. Ambient temperature: < 40°C
 2. Normal operating ratings

If the recommended cables for peripheral equipment or options are not suitable for the product, contact the agent or Inovance.

Cable Selection

For details, see ["3.1.4 Cable Selection for Main Circuit" on page 51](#)[Cable Selection for Main Circuit](#).

Requirements on Protective Devices

- To meet the requirements of UL standards, a fuse/circuit breaker must be connected on the input side to prevent accidents caused by internal short circuits.
- Install adequate branch circuits for short circuit protection in accordance with applicable regulations and the requirements in this user guide. This product is suitable for circuits with a short circuit current lower than 100 kA, and the maximum voltage of 480 VAC (400 V). For details about the selection of the fuse/circuit breaker, see ["4.1.1 Fuse, Circuit Breaker, and Contactor" on page 94](#)[Fuse, Circuit Breaker, and Contactor](#).

Shenzhen Inovance Technology Co., Ltd.

Add.: Building E, Hongwei Industry Park, Liuxian Road,
Baocheng No. 70 Zone, Bao'an District, Shenzhen

Tel: +86-755-2979 9595

Fax: +86-755-2961 9897

<http://www.inovance.com>

Suzhou Inovance Technology Co., Ltd.

Add.: No. 16 Youxiang Road, Yuexi Town, Wuzhong
District, Suzhou 215104, P.R. China

Tel: +86-755-2979 6666

Fax: +86-755-2961 6720

<http://www.inovance.com>



19011492A00